

AMSY-6

System Specification

Document released in April 2015

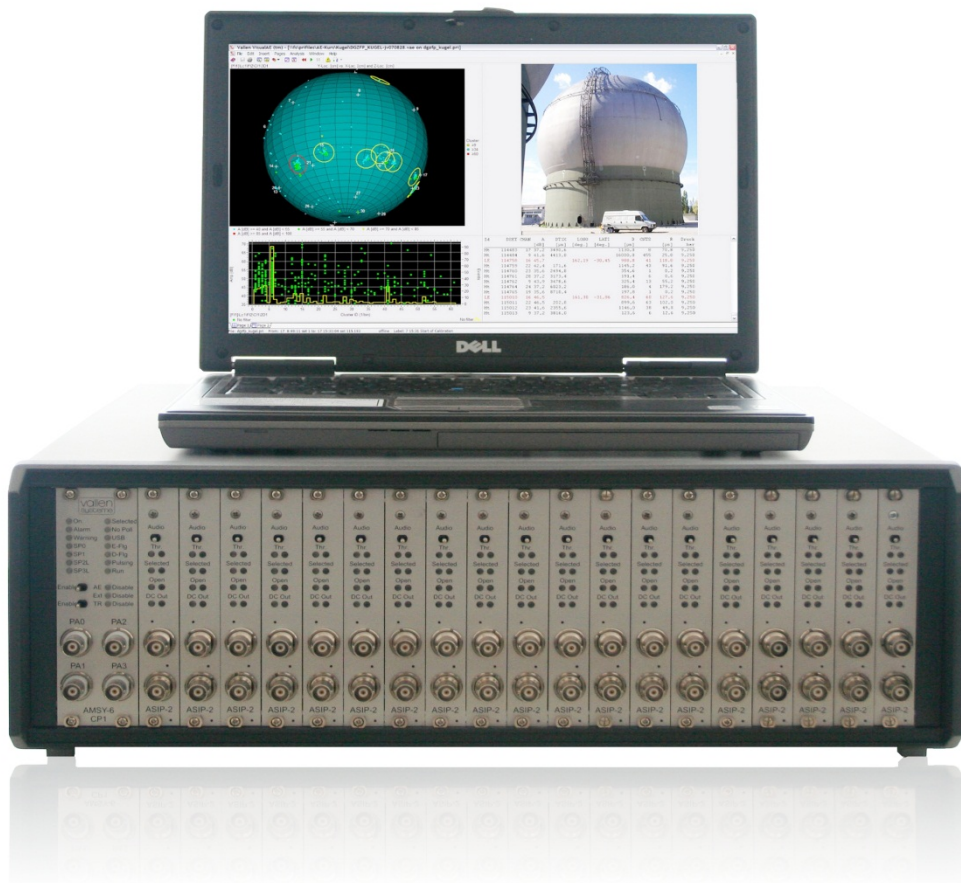

Contact Address

Vallen Systeme GmbH
Schaeftlarnner Weg 26a
D-82057 Icking
Germany

email: info@vallen.de
<http://www.vallen.de>

Tel: +49 8178 9674-400
Fax: +49 8178 9674-444

Specifications are subject to change as product developments are made.

Comments and recommendations are appreciated and may be mailed to: sales@Vallen.de

Copyright © 2014, Vallen Systeme GmbH

All rights reserved.

Electronic versions of this document may be read online, downloaded for personal use, or referenced in another document as a URL to a Vallen website. No part of this specification may be published commercially in print or electronic form, edited, translated, or otherwise altered without the permission of Vallen Systeme GmbH.

Trademarks and Licenses

The hardware and/or software described herein are furnished under a license and may be used or copied only in accordance with the terms of such license.

AMSY-5, AMSY-6, ASIP-2, VisualAE, VisualClass and VisualTR are trademarks of Vallen Systeme GmbH

Disclaimer

The material contained in this document is provided "as is" and is subject to being changed, without notice, in future editions. Further, to the maximum extent permitted by applicable law, we, Vallen Systeme GmbH, disclaim all warranties, either expressed or implied with regard to this specification and any information contained herein, including but not limited to the implied warranties of merchantability and fitness for a particular purpose. We, Vallen Systeme GmbH, shall not be liable for errors or for incidental or consequential damages in connection with the furnishing, use, or performance of this document or any information contained herein.

We shall not be liable for any direct, indirect, consequential or incidental damage arising out of the use or inability to use of the AMSY-6 and the equipment delivered with it. We reserve the right to charge for any efforts taken to remedy any problems for which we are not responsible.

Revision Record

Date	Changes	Name
04-2015	Added multiple pool groups	AMSY-6_Spec_1504

Purpose of this Document

This document:

- Explains the part codes used in AMSY-6 quotations and helps assembling modules to complete system configurations
- Outlines specifications of the individual system components

Contents

1	Intended Use of AMSY-6	4
2	Chassis	5
2.1	Sizes and weights	5
2.2	Power supply	6
2.3	Power consumption	6
2.4	Environmental conditions.....	6
2.5	Front panel chassis interfaces.....	7
2.5.1	AE-enable / TR-enable switches.....	7
2.5.2	Parametric input channels	7
2.5.3	LEDs	8
2.5.4	Speaker.....	8
2.6	Rear panel chassis interfaces.....	9
2.6.1	Externals Connector.....	9
2.6.2	Alarm Connector	10
2.6.3	Audio Jack.....	11
2.6.4	Address Selector.....	11
2.6.5	Next - / Previous Port.....	11
2.6.6	USB Interface.....	12
2.6.7	Pulse Out	12
2.6.8	Power on/off switch.....	12
3	ASIP-2	13
3.1	ASIP-2/A features	17
3.2	Options for ASIP-2.....	18
4	Preamplifiers	19
5	Sensors.....	19
6	Accessories: cables, magnet holders, etc	19
7	External PC and supported Operating Systems (OS).....	19
8	Vallen AE-Suite Software	20
9	Standard compliance.....	24
10	Warranty Conditions.....	24
11	End User License Agreement (EULA).....	25
12	Regulations concerning redemption and disposal of AMSY-6 systems	26
13	Restriction of Hazardous Substances (RoHS).....	26

1 Intended Use of AMSY-6

AMSY-6 is a multi-channel Acoustic Emission (AE)-measurement system consisting of parallel measurement channels. AMSY-6 can be used to detect, measure and locate AE-sources such as material failure on microscopic level, corrosion, leakage, partial discharge, friction and wear as well as particle impact.

A measurement channel consists of an AE-sensor (see section 5), a preamplifier (see section 4) and one channel of an ASIP-2 (dual channel acoustic signal processor, see section 3).

ASIP-2 boards are mounted in a chassis which is connected via an USB interface to a PC. Up to eight chassis can be paralleled on the USB hub. Each chassis has various interfaces, which are described in section 2.5 and 2.6. Additionally an AMSY-6 may have up to 16 parametric channels (PaX; see section 2.5.2) for measuring environmental conditions such as temperature, load, humidity, wind speed, etc.

The system front-end (see section 8) is running on a PC (see section 7). It controls and initializes the measurement system and stores the results. The analysis software VisualAE, VisualTR and VisualClass can be operated on-line to achieve an on-line measurement and analysis system.

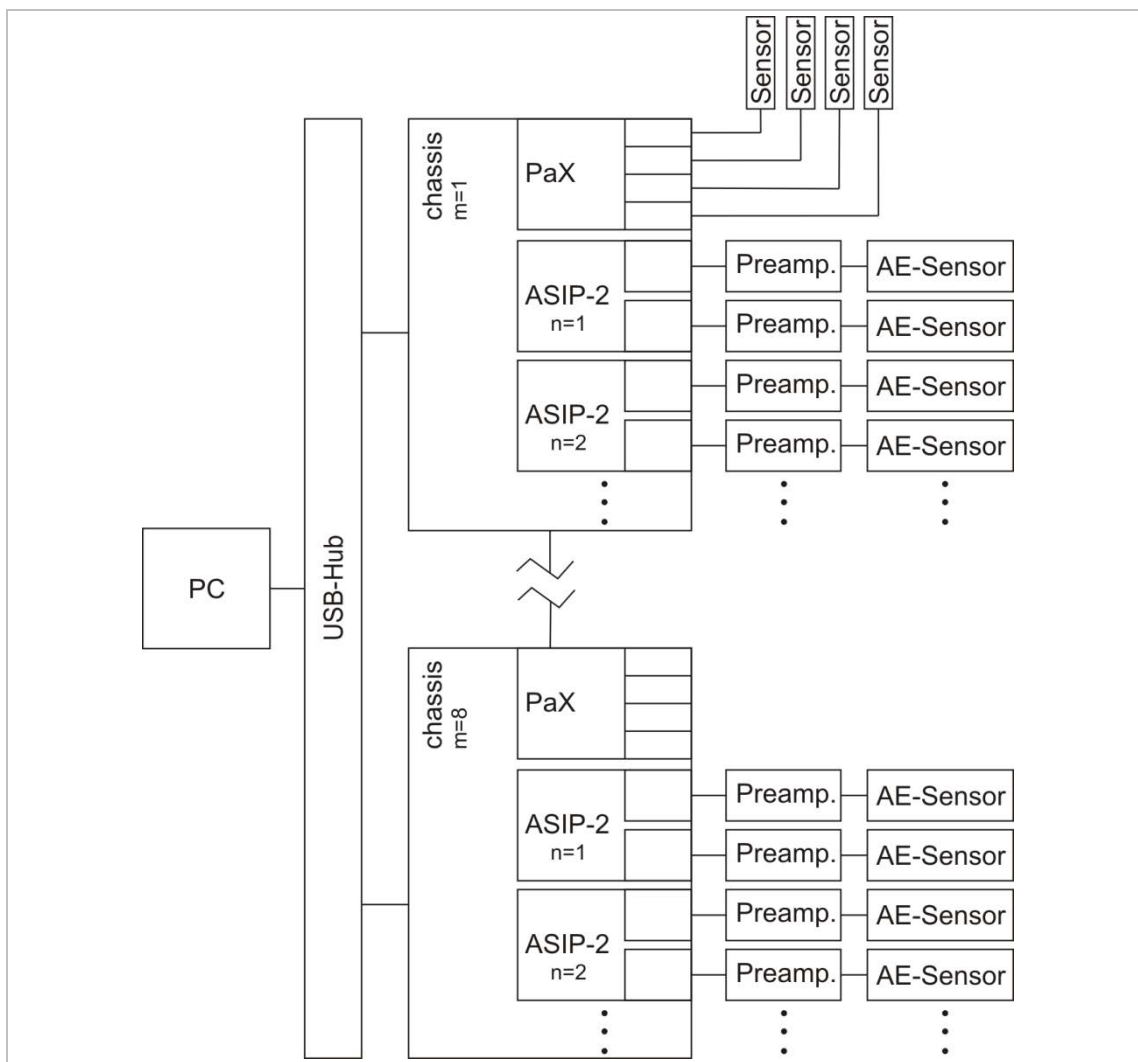

Figure 1: Block diagram of an AMSY-6

AMSY-6 setup performance parameters

Parameters	Limit
Maximum number of chassis (MBx/MR19, EB21/ER21) in a multi chassis setup	8
Maximum number of AE-channels with or without transient recording	254
Maximum number of parametric input channels in a multi chassis setup	16
Maximum number of parametric channels in MB19/MR19 or MB6 chassis	8
Maximum number of parametric channels in MB2 chassis	4

2 Chassis

The chassis holds the acoustic signal processors (ASIP-2), parametric channels, control panel and various interfaces described in the subsequent sections.

Up to 8 chassis can be interconnected in a multi chassis setup. The chassis with the lowest address setting acts as master chassis. All other chassis are considered slave chassis.

Chassis` are available in a standalone version, abbreviated MBx or EB21 and a rack mountable version abbreviated MR19 or ER19.

2.1 Sizes and weights

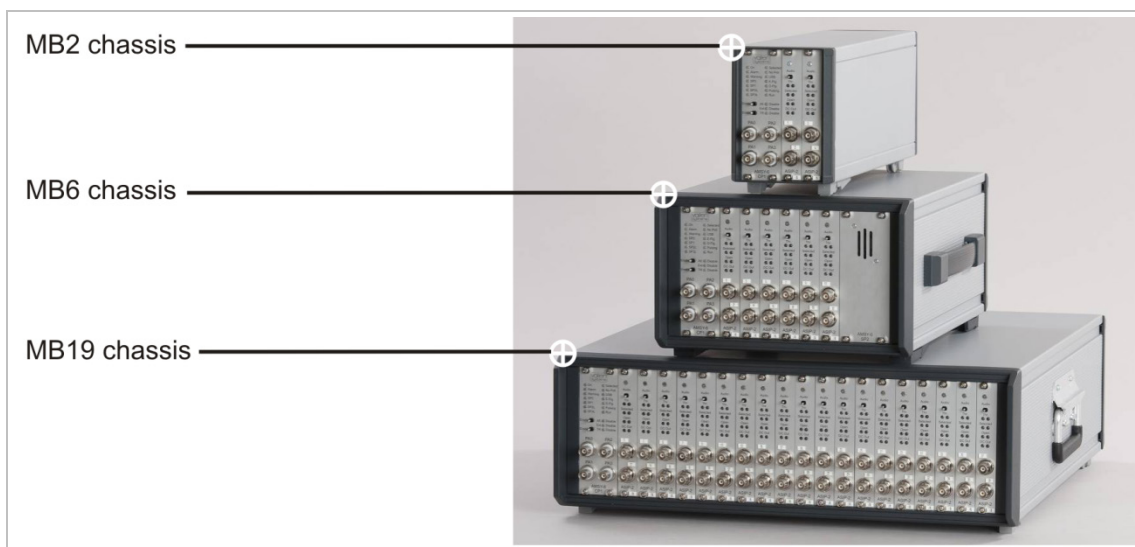

Figure 2: MB2, MB6 and MB19 chassis with 4, 12 and 38 AE-channels, respectively.

A chassis is available in different sizes identified by the chassis codes.

Chassis Code	Size in cm (width x height x depth)	Max. AE-channel number	Weight in kg
MB2	10.5 x 15 x 40.5	4	3.4
MB6	27 x 17 x 39	12	5.8
MB19	48 x 17 x 51	38	10.4
MR19	48.3 x 17.7 x 52 (4HE 84TE)	38	10.0

EB21	48 x 17 x 51	42	10.2
ER21	48.3 x 17.7 x 52 (4HE 84TE)	42	9.8

Additional information for rack mountable chassis types MR19 and ER21:

Chassis types MR19 and ER21 are intended for horizontal mounting in 19" racks. For easy mounting and stability reasons slides/rails in the rack must be used (not part of chassis delivery). The chassis is placed on this rail and fixed with front screws.

The rack must be open at front and rear to allow for free flow of cooling air.

The power switch at the rear of the chassis must be accessible.

The chassis needs a height of 4 rack units (177,8 mm), a width of 84 pitch units (426,7 mm) and a depth of 506 mm.

We recommend to consider 1-2 additional rack units as free cable place in case you want to run the cables to the preamplifiers from the front connectors to the rear.

2.2 Power supply

Power supply	Description
Input voltage	Nominal: 100 – 240V _{AC} , 50 – 60Hz Working: 85 – 264V _{AC} , 47 - 63Hz
Connector type	IEC C14
Ground socket	4mm banana jack

2.3 Power consumption

Chassis Code	Per ASIP-2 (w. TR2/2GB) [VA]	Per preamplifier (in saturation) [VA]	Max. (max. number of ASIP-2 mounted in chassis) [VA]
MB2	10	4.5	65
MB6			150
MB19			410
MR19			410
EB21			450
ER21			450

2.4 Environmental conditions

AMSY-6 is intended for interior use, only.

Environmental conditions	Description
Temperature range	+5°C – +40°C
Relative Humidity	Maximum relative humidity of 80% at 31°C Linear decrease of relative humidity to 50% with increasing

	temperature up to 40°C
Maximum altitude	2000m
Pollution degree	2

2.5 Front panel chassis interfaces

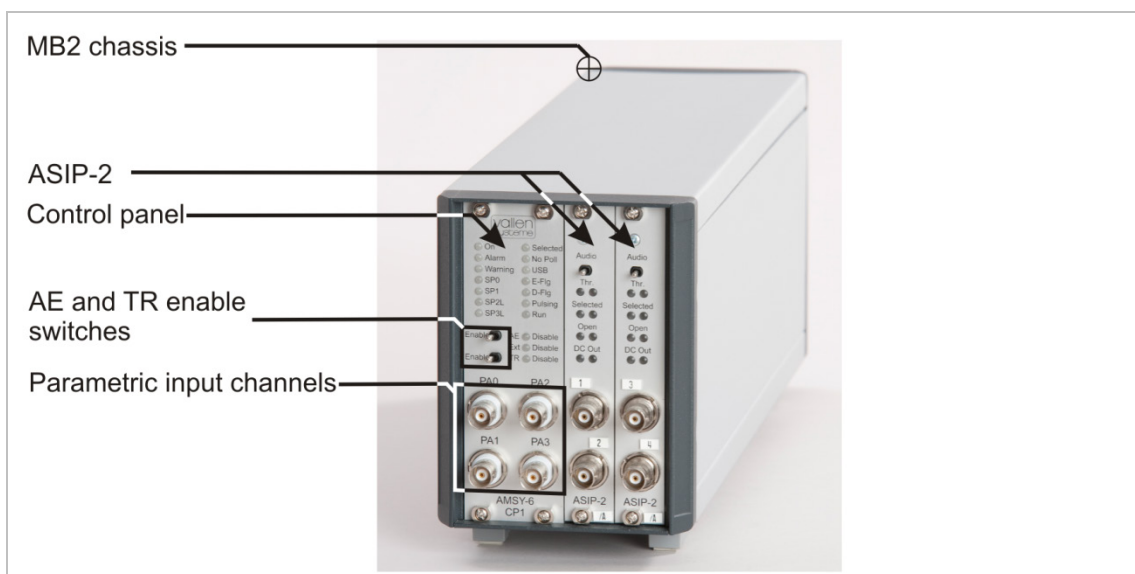

Figure 3: Front side of MB2 with front panel elements: ASIP-2 (chapter 3), AE-enable and TR-enable switch (2.5.1) and parametric input channels (2.5.2).

2.5.1 AE-enable / TR-enable switches

Switch	Description
AE-enable	Switch that enables or disables data acquisition (AE-data as well as TR-data).
TR-enable	Switch that enables or disables acquisition of TR-data, only

2.5.2 Parametric input channels

Item	Description
Input range	Software selectable: $\pm 1V$ or $\pm 10V$
Common mode voltage	Input range of $\pm 10V$: $\pm 30V$ (max) Input range of $\pm 1V$: $\pm 39V$ (max)
Input impedance (to ground)	100k Ω
Input impedance (differential)	200k Ω
Parametric clock (scan rate)	$N \times 50\mu s$; $N=2,3,\dots,200$
Averaging (low pass)	N samples, N as defined for parametric clock
Resolution	16bit

Overvoltage protection	±48V inner wire and shield against ground
------------------------	---



Note:

The shield potential shall be connected to a low impedance reference potential at source side.

2.5.3 LEDs

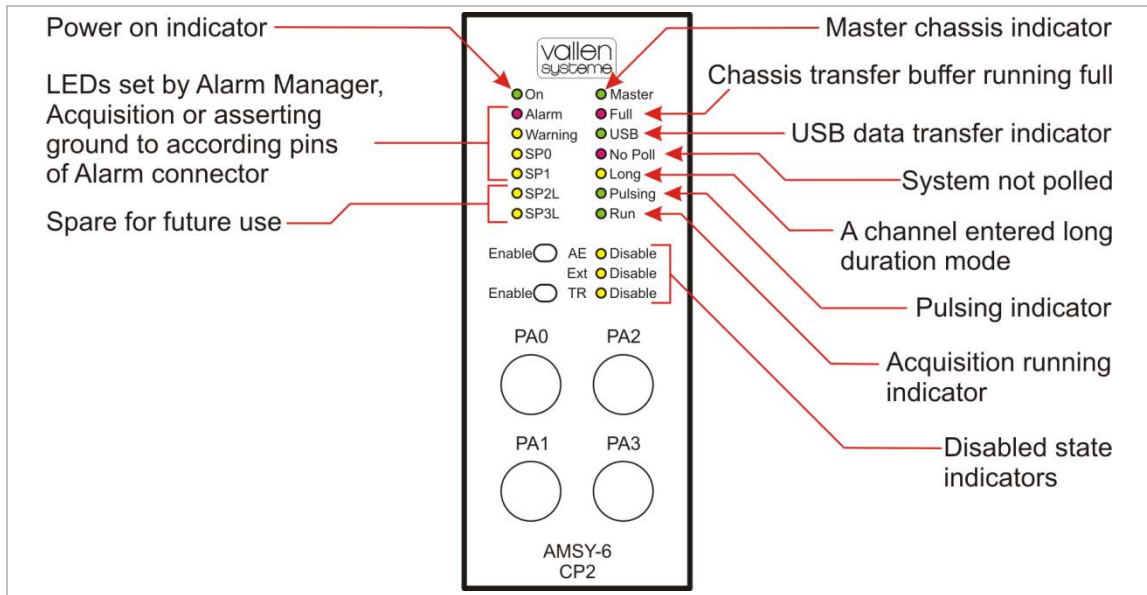

Figure 4: Control Panel LEDs

Control Panel LEDs (CP1 or CP2)

CP1 is used in MB2, MB19 and MR19, CP2 in MB6. CP1 and CP2 vary slightly in width.

For a functional description of Control Panel LEDs see the AMSY-6 System Description document.

Supply Monitor (SM1)

LED	Description
DC ok (SM1)	All DC voltages are generated by the power supply (available only in MB19 and MR19)
AC on (SM1)	AC voltage input ok (available only in MB19 and MR19)

2.5.4 Speaker

Internal speaker for audio output of frequency filtered AE signal of all audio selected AE channels (see chapter 3 section Mechanical properties).

An internal speaker is only available in chassis MB6 (front speaker), MB19 and MR19 (rear speaker, front speaker is optional) or EB21 and ER21 (rear speaker, front speaker is optional).

2.6 Rear panel chassis interfaces

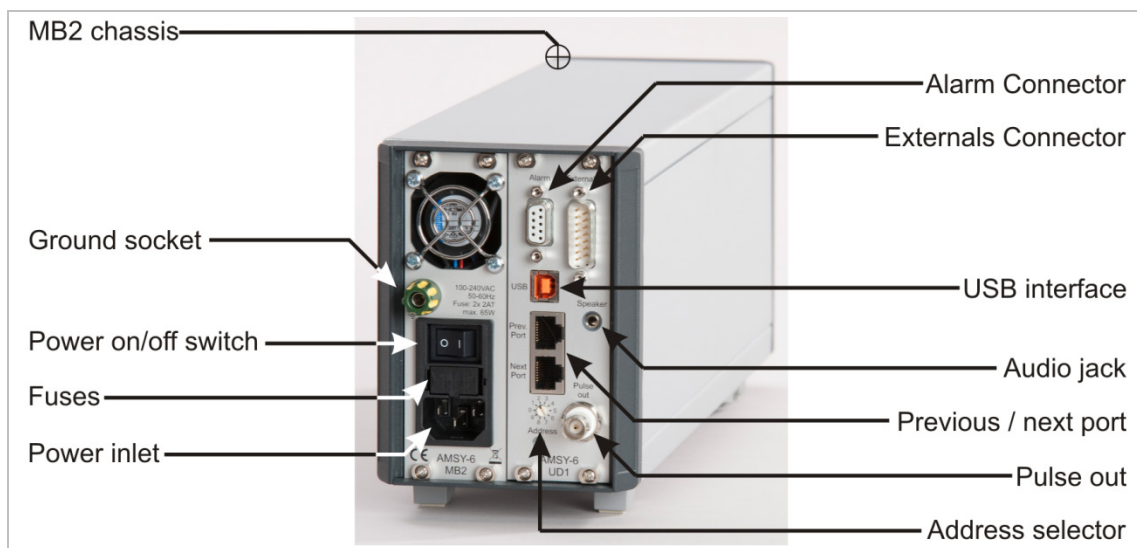

Figure 5: Rear side of MB2 with back panel elements: grounding post, power on/off switch (2.6.8), power inlet (2.2), alarm connector (2.6.2), externals connector (2.6.1), USB interface (2.6.6), audio jack (2.6.3), previous/next port (2.6.5), pulse out (2.6.7) and address selector (2.6.4).

2.6.1 Externals Connector

The externals connector is a 15-pole male D-sub connector which provides access to the following functions:

- External record control
- Control of the digital parametric counter PCTD
- I2C interface
- User defined DAC Output
- External trigger input

Pin	Signal	Description
1	I ² C Clock	External I ² C bus clock line
2	GND	Logic ground.
3	GND	Logic ground.
4	GND	Logic ground.
5	GND	Logic ground.
6	GND	Logic ground.
7	GND	Logic ground.
8	/DISABLE	Low disables AE- and TR-recording and switches on the LED "Ext. Dis"
9	I ² C Data	External I ² C bus data line.
10	User-DAC	User defined analog output, 0-5V at 10mA max.

Pin	Signal	Description
11	PCTD-Clock	Every rising or falling edge increments/decrements the PCTD counter maximum counting frequency: 160kHz
12	PCTD-up/down	High or open: PCTD increments Low: PCTD decrements
13	PCTD-enable	High or open: enables counter Low: disables counter
14	PCTD-reset	High or open: PCTD is set to 0 (asynchronous to PCTD-Clock) Low: the current PCTD value is stored
15	ETRIG	Spare for future use

Notes:

- Pin 1, 9: Bidirectional open drain signals with 10kOhm pull-ups to +5V. Shall be driven to ground only.
- Pin 10: Output of signal. No external voltage shall be applied at this pin.
- Pin 8, 11 to 15: TTL input signals with 10kOhm pull-ups to +5V.
- All signals are protected against electrostatic discharge transients up to 15kV (human body model)
- PCTD: current value of digital counter is stored with parametric data set. Parametric data sets are usually stored asynchronous to PCTD-clock. Last value of PCTD might not be stored when PCTR-reset is detected before next parametric data set is stored.



WARNING:

Voltages between 0 and +5V against GND (pins 2 to 7) are allowed at TTL input signal pins (#8, #11 to #15) when the unit is powered and switched on.



Note:

The Externals connector should be used in a master chassis only. The signals are undefined in a slave chassis

2.6.2 Alarm Connector

The Alarm connector is a 9-pole female D-sub connector with the following pin out:

Pin	Signal	Meaning
1	+5V	+5V, max 60mA, protected by a PTC resistor
2	GND	Logic ground.
3	GND	Logic ground.
4	GND	Logic ground.
5	GND	Logic ground.
6	ALARM	Driven low when ALARM LED is on under software control. If driven low externally, ALARM LED is on.
7	WARN	Driven low when WARNING LED is on under software control. If driven low externally, WARN LED is on.

Pin	Signal	Meaning
8	SP0	Driven low when SP0 LED is on. If driven low externally, SP0 LED is on.
9	SP1	Driven low when SP1 LED is on. If driven low externally SP1 LED is on.

Notes:

- Pin 6 to 9: Bidirectional open drain signals with 10kOhm pull-ups to 5V.
- All signals are protected against electrostatic discharge transients of up to 15kV (human body model)



Note:

Alarm connector should be used in a master chassis only. In a slave chassis the outputs are undefined and inputs control only corresponding LEDs without further effect.

2.6.3 Audio Jack

The audio jack can be used to connect an external passive speaker. If an external audio device is attached the internal speakers are disabled. Both audio channels are driven from the same mono signal.

Item	Connector Type	Size	Impedance
Audio out	TRS jack	Miniature: 3.5mm diameter	8Ω



WARNING:

Do not use TS type connector (mono), a headphone or active speaker!

2.6.4 Address Selector

The address selector is a rotary switch which defines the address of a chassis. In a multi chassis setup, each chassis has to have a unique address and the one with the lowest address is considered the master chassis. Up to 8 chassis can be interconnected to form one large AMSY-6 measurement system.

2.6.5 Next - / Previous Port

In a multi chassis setup the participating chassis have to be connected in a daisy chain via the Next Port / Previous Port connectors for time synchronization reasons.

The Next Port connector is connected to the Previous Port of the next chassis in the daisy chain.

Connector label	Connector Type	Cabling (pin/pair assignment)
Next Port	8P8C (RJ45)	shielded 100-ohm balanced twisted-pair cabling, CAT 5 or better, no-crossover
Previous Port	8P8C (RJ45)	shielded 100-ohm balanced twisted-pair cabling, CAT 5 or better, no-crossover



In a multi chassis setup the AMSY-6 is made up of multiple chassis connected together in a chain via the Next-/Previous Port jack for time synchronization.

2.6.6 USB Interface

Item	Description
USB Specification	USB 2.0 high speed
Connector	USB series B receptacle
Retention force for mating / unmating	35N (max) / 15N (min)



Note:

The 5V line of the USB is not used, so no USB power is required.



Note:

In a multi chassis setup each chassis has to be connected to USB port(s) of PC for data transfer. If PC does not offer enough USB ports a USB-hub can be used.

2.6.7 Pulse Out

Voltage pulses that are generated by the pulser module are delivered to the BNC socket labeled "Pulse Out".

Pulser Voltage	Description
Maximum voltage	450V _{PP} , software selectable

2.6.8 Power on/off switch

Switch that controls the power to the AMSY-6.



Note:

In case of MB19, MR19, EB21 and ER21 this switch is located on the Supply Monitor (SM1).
In case of MB2 and MB6 this switch is located at the power inlet.

3 ASIP-2

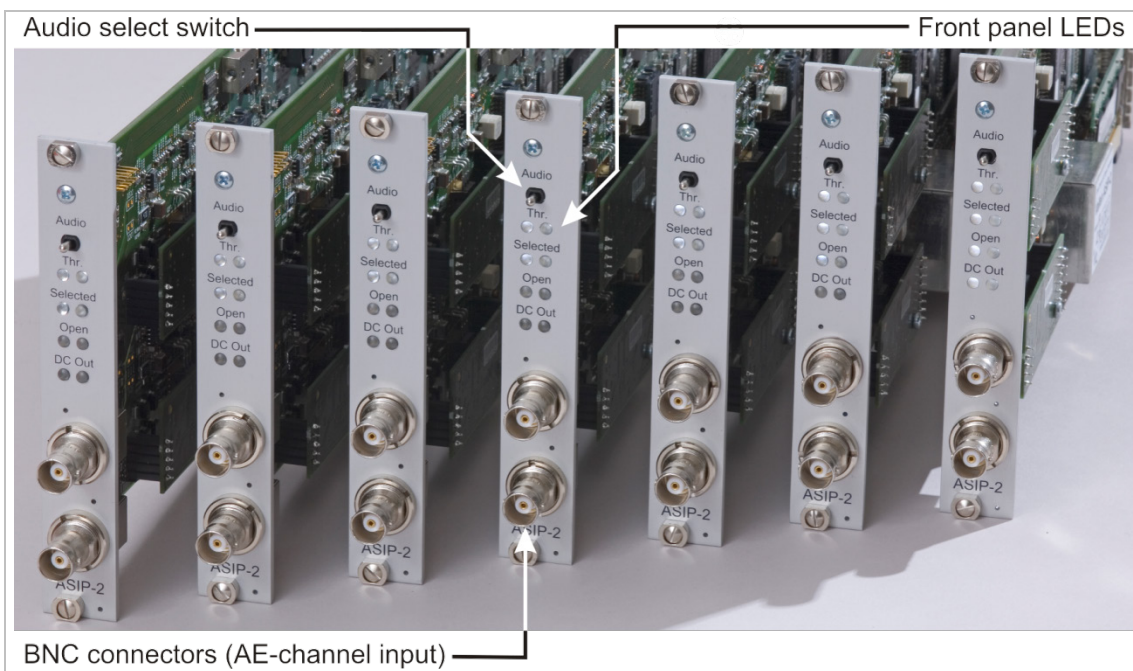

Figure 6: ASIP-2 with front panel elements: audio select switch, LEDs and BNC connectors

ASIP-2 is a dual channel AE-signal processor board which can be mounted in any of the chassis. Each ASIP-2 board and each channel on the board is processing data independent of each other. There are two versions of the ASIP-2:

- ASIP-2/S: standard version or
- ASIP-2/A: advanced version.

Both ASIP-2 versions can be used simultaneously within the same chassis. Following tables describe ASIP-2/S.

Mechanical properties

Mechanical properties	Description
Dimensions	Eurocard plug-in 100mm x 280 mm
Weight	0.32kg
Connectors	2x BNC, input impedance: 50Ω or 100kΩ
Flip switch	Toggles audio on/off (one position per channel)
Front panel LEDs	LEDs indicating threshold crossing, preamplifier saturation, preamplifier connected, DC-output overload, AC/DC input mode, pulsing mode, audio-selection (makes AE signal audible).
Transient recording (TR) memory	Each ASIP-2 can house one transient recorder storage module of type TR-2/xxMB (see section 3.2) to store waveforms in parallel to the classical AE features per channel.

Electrical properties

Electrical properties	Description
System noise	1.5 μ V _{RMS} , 6 μ V _P ; (95-300kHz filter, referred to \pm 100mV _{PK} range at preamplifier input; preamplifier not connected)
Preamplifier power supply	28V _{DC} @50 Ω (see also input devices)
Input devices	Software selectable: 28V _{DC} @50 Ω or AC@100k Ω

ASIP-2/S Signal processing

Signal processing	Description
Analogue band pass filters	1.6 or 18kHz (switch selectable) – 2.4MHz (at -3dB attenuation)
ADC	40MHz at 16 bit per channel
FIR low pass	Cut off: 3.6MHz (-6dB) at 40MSPS, 18 bit. Resulting bandwidth considering both, analogue and FIR Filter: 2.2MHz (at -3dB attenuation)
Application specific digital filter	Band-pass filter consisting of low-pass (LP) and high-pass (HP) filter of 8 th order Butterworth each.
Digital filter roll-off attenuation	48dB/octave for LP and HP
Included digital filters	25-45kHz, 25-300kHz, 25-850kHz, 50-300kHz, 50-850kHz, 95-300kHz, 95-850kHz, 230-850kHz, Bypass (wideband option, e.g. required for System Verification and also recommended for Vallen Sensor Tester (VST)). Additional band pass filters available (see section 3.2)
Digital filter selection	Software selectable for each channel individually.

Transient Recording (needs hardware option TR-2)

Transient data recorded to onboard DRAM. For available sizes of onboard DRAM see section 3.2

Transient Recording	Description
Sample interval	Programmable between 625kHz to 10MHz (1-16x0.1 μ s), globally valid for all AE-channels
Maximum samples per record	2M samples
Pretrigger	Individually programmable per AE-channel up to 64k samples
Trigger modes	Four trigger modes defined globally across multiple chassis for individual Trigger groups: Internal-, Pool- (Pool-trigger is when the first-hit channel simultaneously triggers all transient recorders of channels defined as Pool or Slave), Master- (Master triggers its own transient recording plus transient recording of all Slave and Pool channels) and Slave- (transient recording of slave channels can only be triggered by a Master channel) trigger.

Transient Recording	Description
Trigger group	A subset of channels, even across multiple chassis can be assigned to a trigger group. Trigger modes are applied per trigger group. The first hit channel of a trigger group triggers the other channels according to the selected modes. Each channel can be assigned to one trigger group, only
Recording modes	Two recording modes: Fixed page length recording: a predefined number of samples is recorded per trigger Duration adapted recording: number of samples that are recorded per trigger depend on duration of hit, pretrigger samples and post duration samples; maximum length of record is 2M samples.

Hit assembly

Hit assembly parameters	Description
Threshold	Software selectable for each AE-channel individually. Fixed or floating threshold.
Duration discrimination time (DDT)	A time setting used for discriminating hits
Rearm time (RAT)	A timer setting used for discrimination hit cascades

Feature extraction

Dual core feature extractor with loadable firmware for optimum flexibility.

Hit processing	Description
Sampling rate	10MHz
Arrival time resolution	100ns
Arrival time bit width	63bit
Peak amplitude resolution	Max (0.375dB, 76.3 μ V/Gain)
Threshold resolution	Max (0.375dB, 76.3 μ V/Gain)
Rise time resolution	Max (200ns, 0.025%)
Duration resolution	Max (200ns, 0.025%)
Ring down count resolution	16bit
Hit cascade ¹ features	Number of cascaded hits, cascaded counts, cascaded energy and cascaded signal strength of the complete hit cascade ¹ . Maximum number of hits in a hit cascade: 127
Hit flags	Hit flags indicating a time-out-hit, artificially started hit, hits because of pulses (active and passive), saturation of ADC

¹ Hit cascade: A hit cascade consists of hits that follow each other within an interval less than the rearm time (RAT). Features of a hit cascade are number of hits, sum of ring down counts and sum of energy of hits in a cascade. These features are part of the data set generated with the first hit of a cascade.

	and many more.
Energy calculation	True Energy
Hit processing	Description
Energy resolution	$1.8 * 10^{-18} V^2s$ referred to sensor signal at 34dB preamplifier gain.
Energy units	$1 \text{ eu} = 10^{-14} V^2s$
True RMS resolution (true RMS before a hit)	<1 μV resolution referred to sensor signal at 34dB preamplifier gain.
True RMS resolution of a hit	<1 μV resolution referred to sensor signal at 34dB preamplifier gain, needs SW-option VAEUPE: User Processor Extension
Signal Strength resolution	0.3pVs referred to sensor signal at 34dB preamplifier gain.
Signal Strenght units	nVs = $10^{-9} Vs$
Average noise level before a hit	<1 μV resolution referred to sensor signal at 34dB preamplifier gain.
Average noise level of a hit	<1 μV resolution referred to sensor signal at 34dB preamplifier gain; needs SW-option VAEUPE: User Processor Extension

Hit time-outs

A hit is artificially terminated after about 100ms. An artificial hit is started automatically after a hit is timed-out. A hit that is timed-out and thus terminated is assigned a “time-out” hit flag. A hit that is artificially started is assigned an “artificially started” hit flag.

Hit processing performance

About 19,000 hits/second (peak) can be filled into the buffer of each AE-channel, 100,000 hits/second can be transferred to the PC and stored on the hard disk drive continuously, in parallel with data analysis program.

Above 100,000 hits per second a buffer overflow of hit-data is avoided by setting the respective ASIP-2 into long duration mode, when the ASIP-2 buffer runs half full. The whole chassis is set into long duration mode if the USYC buffer runs 80% full.

Status data

Status data is generated per time interval. The time interval is software selectable. Following status data is generated:

- RMSS: RMS at the time of the generation of a status data set. RMS is calculated exclusive AE-signals that are part of hits.
- ENYS: True Energy cumulated between two status data sets
- SSS: Signal strength cumulated between two status data sets
- THRS: threshold at the time of the generation of a status data set

3.1 ASIP-2/A features

The ASIP-2/A fulfills the ASIP-2/S specification (see section 3). Additional features are listed below:

Electrical properties (additional to ASIP-2/S)

Electrical properties	Description
Preamplifier power supply	Software selectable: 28V _{DC} @50Ω (see also input devices), 8-28 V _{DC} (programmable voltage) @ 200Ω, 8-28 V _{DC} (programmable voltage) @ 50Ω
Input devices	Software selectable: 28V _{DC} @50Ω, AC @100kΩ, 8-28V _{DC} @200Ω, 8-28V _{DC} @50Ω

Signal processing (additional to ASIP-2/S)

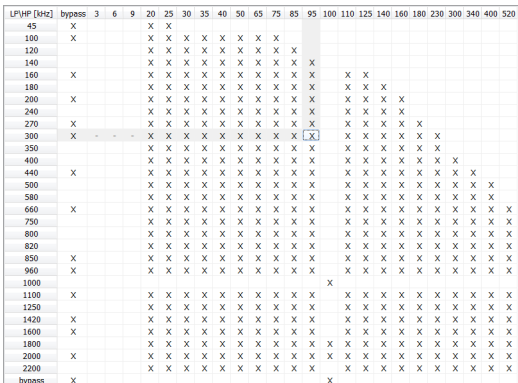
Signal processing	Description
Application specific digital filters	<p>over 500 band pass filters available</p>  <p><i>Figure 7: matrix of available filters for up to 20MHz sampling rate. Rows for low pass-, columns for high pass selection</i></p>
Digital filter order	8 th order Butterworth at up to 20MSPS (each high- and low pass) 4 th order Butterworth at 40MSPS (each high- and low pass)
Transient recording (TR)	Up to 40MSPS (requires TR-2)
Input ranges	Three software selectable input ranges (10Vpp, 5Vpp, 2.5Vpp) for better resolution for applications with low amplitude.
Notch filter stage	<p>Notch filter rejects user-selectable frequencies.</p> <p>Max. notch filter frequency: 250kHz (8th order) or 500kHz (4th order)</p> <p>Notch filter rejects:</p> <ul style="list-style-type: none"> at 10MHz sampling rate: 4 frequencies each 2nd order. at 20MHz sampling rate: 2 frequencies each 2nd order. at 40MHz sampling rate: 1 frequency of 2nd order.

Feature extraction (additional to ASIP-2/S)

Hit processing	Description
Arrival time resolution	100ns, 50ns or 25ns (software selectable)
Arrival time bit width	63bit

3.2 Options for ASIP-2

Application specific filters (ASIP-2/S only)

Any number of application specific filters can be enabled for an ASIP-2/S.

Item-code	Description
DigBP-2/ <i>hi-pass – low-pass</i>	One digital band-pass filter configuration for one ASIP-2 (i.e. for two channels). Over 500 digital band-pass filters are available for selection (see the table below)

Select corner frequencies from the following lists:

Filter type	Corner frequencies
Hi-Pass [kHz]:	3.1 ⁺ , 6.2 ⁺ , 9.3 ⁺ , 12.4 ⁺ , 17 ⁺ , 20 ⁺ , 20, 25, 30, 35, 40, 50, 65, 75, 85, 95, 100*, 110, 125, 140, 160, 180, 230, 300, 340, 400, 520
Low-Pass [kHz]:	45, 100, 120, 140, 160, 180, 200, 240, 270, 300, 350, 400, 440, 500, 580, 660, 750, 800, 820, 850, 960, 1100, 1250, 1420, 1600, 1800*, 2000*, 2200*

Examples

DigBP-2/95-300 means digital bandpass 95-300kHz,

DigBP-2/25-1420 means digital bandpass 25-1420kHz

⁺ For these high-pass filters the switch on the analog filter shall be “ON” (for 1.6kHz high-pass), otherwise “OFF” (for 18kHz high-pass). Signal processing of frequencies below 12 kHz needs input mode “AC@100K” (no DC supply for preamplifier possible).

* These filters are of 4th order running at 40MHz.

Transient recording memory

Item-code	Description
TR-2/2GB	2GB TR module for ASIP-2 (1 GByte per channel)
TR-2/512MB	512MB TR module for ASIP-2 (256 MByte per channel)
TR-2/16MB	16MB TR module for ASIP-2 (8MB per channel)

4 Preamplifiers

For information about preamplifiers please see separate specification “Acoustic Emission Preamplifier” (available on www.vallen.de, on the Vallen AE Suite CD ROM, or from sales@vallen.de).



5 Sensors

For information about sensors please see separate specification “Acoustic Emission Sensors” (available on www.vallen.de, on the Vallen AE Suite CD ROM, or from sales@vallen.de).



6 Accessories: cables, magnet holders, etc

For information regarding cables, magnet holders, and other accessories please see separate specification “Accessories” (available on www.vallen.de, on the Vallen AE Suite CD ROM, or from sales@vallen.de).



7 External PC and supported Operating Systems (OS)

The external PC controls the measurement hardware, runs the system front-end and stores the measurement data. Any kind of PC, e.g. desktop, lunchbox, 19” rack industry standard PC with an USB2.0 Hi-Speed interface can be used.

PC Requirements	
OS	Windows XP, Windows Vista, Windows 7 (recommended); for AMSY-5 32bit OS; for AMSY-6 64bit OS.
CPU	minimum: dual core processor CPU, 32-bit (x86) or 64-bit (x64), > 2GHz, recommended is a quad core CPU.
RAM	minimum of 2 Gigabyte (GB) in case of Windows XP, recommended is 4GB for 32bit OS or more in case of 64bit OS
HDD	NTFS format, 1 GB free disk space for program installation, depending on your test data much more disk space will be needed.

USB	Free USB 2.0 port, external passive USB hub can be used.
-----	--

The following operating systems have been tested with AMSY-6:

Operating System	Data acquisition	Data analysis	APIs
Windows XP 32 bit, SP3	Yes	Yes	OK
Windows XP 64 bit, SP3	Yes	Yes	Not OK
Windows Vista 32 bit, SP2	Yes	Yes	OK
Windows Vista 64 bit, SP2	Yes	Yes	Not OK
Windows 7 32 bit	Yes	Yes	OK
Windows 7 64 bit	Yes	Yes	Not OK
Windows 8 64 bit	Yes	Yes	Not OK



Note:

The APIs (Application programming interface) we provide for our software are compiled in 32 bit only. Therefore, a program which uses an API has to be compiled in 32 bit, too. For example if another program (e.g. Excel or Matlab) shall interact with e.g. Alarm Manager or Acquisition via an API, it must be a 32 bit version.

We provide following APIs:

- AcqCmdAPI to control acquisition e.g. by a batch file.
- Alarm manager's external action to execute an external program or script triggered by a warning or an alarm.
- XTR (option) to read waveform data from TR-file.

If these APIs are not used, then Vallen AE-Suite software can be installed on a 64bit OS.

8 Vallen AE-Suite Software

The Vallen AE-Suite Software is made up of individual modules. A module can contain a stand-alone application, e.g. VisualAE, VisualTR, VisualClass, etc or enhancements to existing software (e.g. location- and data processor modules). If a module consists of a number of applications – which is usually the case – it is also referred to as a software package. A module or package provides certain functionality, such as data acquisition, hardware management, data analysis, system verification, etc.

A software license grants the user the right to use single – or all functions that a module provides. These rights are governed by so called options, i.e. an enabled option grants the right to use certain (possibly all) functions of a module.

A software bundle consists of a number of modules but is identified by a single option in the software license.

A detailed description of software modules and software functionality is given in the AMSY-6 System Description document, available from Vallen Systeme GmbH.

Basic software modules

Option Code	Description
SWACQ	Data acquisition software package. Contains Acquisition program which manages data recording, data storage and acquisition settings. Contains Hardware Reporter, ADC-Test, TR-Test, and Firmware Updater (price included within the AMSY-6 hardware price).
SWBN	Basic software package for the analysis of AE-data and AE-waveforms, inclusive extensive and context-sensitive online-help, includes VisualAE™, Control Panel, Key Reporter, Key Setup, PRI2DB, Pri-Glue, DTA Converter, VAC-Editor, Scheduler and Alarm Manager.
VAE1+2	Extension module extends diagram capabilities (right y-axis, multi-plane support, export of diagram data), captions and comments for visuals, 3D-diagram support, freely position visuals, picture overlay, listing export, page layouts, page export to bitmap, Library support for visuals and processors, support of transient feature file. PCTA-Counter Extender: expands 16bit counter to 32bit on existing data; PAx-Modifier: manually modifying parametric data3 waveform viewer
VTR	Software for the efficient analysis and management of transient recorder data (waveforms), includes VisualTR™, new Spectral Ratio Extractor, FFT-Feature Extractor, FFT Averager, TR-Copy, TR-Combi, TR-filter and TR-Unifier.
VCL	VisualClass™ pattern recognition and classification software

Location Processor module (enhances VisualAE)

Option Code	Description
VAELL	Linear location algorithm locates AE-sources between two sensors
VAELP	Planar location algorithm locates AE-sources on plates or cylindrical hulls in between the area which is bounded by the sensors.
VAELS	Spherical location algorithm locates AE-sources on the spherical hull
VAELTB	Tank-bottom location algorithm locates AE-sources on the bottom of a tank-floor. The sensors have to be mounted along the outer hull of the storage tank.
VAEL3D	Location processor algorithm that locates AE-sources in a volume.
VAELMG	Multi group extension for the location processor
VAELAC	Amplitude correction: based on linear attenuation it calculates the amplitude at the source locations

Data Processor module (enhances VisualAE)

Option Code	Description
VAEFP	Filter processor: filters data based on logical criteria
VAEPP	Polygon processor: assigns polygon ID to hits within a polygon. Can be used as a graphical filter
VAECP	Cluster processor: clusters data according to user-defined attributes
VAEUP	User processor: performs simple mathematical operations on acquired data.
VAEUPE	User processor extension: performs more complex mathematical operations on acquired data.

Embedded Code Processor module (enhances VisualAE)

Option Code	Description
VAECPU	ECP-user license. Allows to execute ECP code in VisualAE
VAECP	ECP-programmer license, allows to write, debug, and execute ECP-code in VisualAE
VAECPV	ECP-validator license, allows to protect and sub-license, to write, debug, and execute ECP-code in VisualAE

Application Programming Interface

Option Code	Description
XTR	ActiveX interface for transient data files. XTR requires a 32bit host application. XTR can be used with e.g. Matlab © 32 bit version, LabVIEW© 32 bit version, Python 32 bit version, etc. XTR cannot be used with a 64bit host application!

Verification software

Option Code	Description
VSTSW	Vallen sensor tester software
SysVeri	semi-automated verification of AE-system, ASIP-2 and ASIPP.

Software bundles

Option Code	Description
BDSWB	<p>Software package for the analysis of AE-data and AE-waveforms, inclusive extensive and context-sensitive online-help, includes VisualAE™. Designed for 32-Bit-Windows. Comprises a license for using the analysis software on up to 5 separate Windows PCs.</p> <p>Comprises the following software modules:</p> <p>SWBN software for analysis of AE + TR-data</p> <p>VAE1+2 Extension module, expands VisualAE™</p> <p>VAEFP Filter Processor</p> <p>VAEUP User Processor</p> <p>VAEUPE User Processor Extension</p> <p>VAEPP Polygon Processor</p> <p>DTACV Converter: dta to pri+tra files</p>
BDSWBupg	<p>Upgrades SWBN to BDSWB, contains</p> <p>VAE1+2 Extension module, expands VisualAE™</p> <p>VAEFP Filter Processor</p> <p>VAEUP User Processor</p> <p>VAEUPE User Processor Extension</p> <p>VAEPP Polygon Processor</p> <p>DTACV Converter: dta to pri+tra files</p>
BDSWLoc1	<p>Location software package, adds location functionality to SWBN or BDSWB, comprises the following software modules:</p> <p>VAELL Linear location module</p> <p>VAELP Planar/Cylindrical location module</p> <p>VAELMG Multi-Group extension for location modules</p> <p>VAECP Cluster Processor</p> <p>VAELAC Amplitude Correction module</p>

Software update contract

Code	Description
SWupd	Prolongation of the software update contract by 1 year.

Furthermore Vallen AE-Suite software contains freeware such as AGU-Vallen Wavelet, Dispersion and JPegger.

9 Standard compliance

AMSY-6 complies with the following directives and standards.

	Directive	Applicable Standards
EMV	2004/108/EG	DIN EN 61326-1; Elektrische Mess-, Steuer-, Regel- und Laborgeräte - EMV-Anforderungen - Teil 1: Allgemeine Anforderungen DIN EN 61326-2-2; Elektrische Mess-, Steuer-, Regel und Laborgeräte - EMV-Anforderungen - Teil 2-2: Besondere Anforderungen - Prüfanordnung, Betriebsbedingungen und Leistungsmerkmale für ortsveränderliche Prüf-, Mess- und Überwachungsgeräte für den Gebrauch in Niederspannungs-Stromversorgungsnetzen
Safety	2006/95/EG	DIN EN 61010-1:2001: Sicherheitsbestimmungen für elektrische Mess-, Steuer-, Regel- und Laborgeräte - Teil 1: Allgemeine Anforderungen

AMSY-6 complies with following European standards.

Standard	Title
EN13477-1	Non-destructive testing – Acoustic Emission – Equipment characterisation – Part 1: Equipment description
EN13477-2	Non-destructive testing – Acoustic Emission – Equipment characterisation – Part 2: Verification of operation characteristics
EN13554	Non-destructive testing – Acoustic Emission – General Principles

10 Warranty Conditions

The warranty period is two years from the date of its delivery for AMSY-6 hardware and for software. This warranty does not cover the repair of any damage to the products generated by accident or improper handling. For warranty conditions for consumables such as sensors and cables see our documents “AE Sensor Overview” and “Accessories for AE Systems”.

We warrant that the goods as delivered will conform to the given specifications. We do not warrant that software is totally free from errors (See the End User License Agreement hereafter). If notified during the warranty period that the delivered AMSY-6 system contains defects such it does not conform to the specifications, we will make it operate as specified by providing replacement parts or software updates as determined by us, free of costs, and within a reasonable time. If transportation should become necessary, the customer has to provide the permits for export and re-import of replacement parts and bear the costs of transportation.

Except as expressed before, we disclaim all other warranties. We shall not be liable for any direct, indirect, consequential or incidental damage arising out of the use or inability to use of the delivered system. We reserve the right to charge for any efforts taken to remedy any incorrect or user-altered PC configurations or other problems for which we are not responsible.

11 End User License Agreement (EULA)

This License Agreement applies to all Vallen Systeme GmbH ("VS") AE software.

Please read the following terms and conditions before using VS AE software. Your use or installation of VS AE software indicates your acceptance of this License Agreement.

If you do not agree to any of the terms of this License Agreement, then do not install or use this copy of VS AE software.

The software license grants the non-exclusive right to use VS AE software. One license of VS AE software entitles you to install it on up to 5 PCs and use it by up to 5 persons simultaneously. Each VS AE license includes a license for the non-exclusive right to (commercially) use Vallen JPepper on the same PC where the VS AE software is installed. The licenses do not grant title to the software nor copyrights in it.

You may access VS AE software through a network, provided that you make sure that per license not more than 5 users simultaneously use the software. In case of more users please ask for a volume license.

VS warrants that the software as delivered will conform to the given specifications. VS does not warrant that the software is totally free from errors. If notified during the warranty period that the software contains errors such that it does not conform to the specifications, VS will correct this by an update free of costs and within a reasonable time.

No other warranty claims will be accepted. Good data processing procedure dictates that any program be thoroughly tested with non-critical data before relying on it. The user must assume the entire risk of using the program. This disclaimer of warranty constitutes an essential part of the License Agreement.

In no event shall VS, or its owners, officers, employees, affiliates, contractors, or subsidiaries, be liable for any incidental, consequential, or punitive damages whatsoever relating to the use or inability to use VS software.

All rights of any kind in VS AE software which are not expressly granted in this License Agreement are entirely and exclusively reserved to and by VS. You may not rent, lease, modify, translate, reverse engineer, de-compile, disassemble, or create derivative works based on VS software. You may not make VS software available to others in connection with a service bureau, application service provider, or similar business.

If the VS software was purchased in the frame of a complete system, and one or more topics in the VS order confirmation deviate from this License Agreement, the deviating sentence in the signed VS order confirmation shall supersede the corresponding sentence in this Agreement.

12 Regulations concerning redemption and disposal of AMSY-6 systems

We, Vallen Systeme GmbH, are registered manufacturer of the measurement instrument AMSY-6 (WEEE-Reg.-Nr. DE 68150283).

According to German law (§10 subparagraph 2 of Elektro- und Elektronikgerätegesetz – ElektroG) and in the interests of our customers, we accept the obligation for redemption and appropriate disposal of those AMSY-6 systems which have been placed by us on the market within the scope of the before mentioned law, after August 13, 2005.

For this we provide the following procedure:

- Owners of old instruments request our agreement with the return of old instruments. The goods to be returned must be described unambiguously and identified by serial number and/or the identification numbers.
- Upon our approval owners may ship the goods free of costs for us.
- We will dispose the goods according to the relevant laws and regulations on our costs.
- Goods returned without our approval will not be accepted and returned to the owner on his account.

With this measure we wish to serve our customers in the best way to properly dispose old instruments and to contribute to re-use, recycling and proper disposal of electronic waste.



Equipment labeled with the symbol shown left must be disposed separately from unsorted municipal waste within the European Union.

13 Restriction of Hazardous Substances (RoHS)

Vallen Systeme GmbH is collaborating with its suppliers to comply with the European Union Restriction of the Use of Certain Hazardous Substances in Electrical and Electronic Equipment ("RoHS") Directive (2002/95/EC), taking effect July 1, 2006. The RoHS directive prohibits the sale of electronic equipment containing certain hazardous substances such as lead, cadmium, mercury, hexavalent chromium, polybrominated biphenyls ("PBB") and polybrominated diphenylethers ("PBDE") in the European Union.