



JAWS 2.0™



Z-CHECK
CORPORATION

35560 Grand River Ave, #420
Farmington Hills, MI 48335
P: 248-676-1007 / E: sales@z-checkcorp.com
Website: www.z-checkcorp.com

remote visual inspection +
foreign object retrieval

insight into your assets

What you don't know about your critical plant assets and infrastructure can develop into significant risks. Sensor Networks, Inc. delivers the visual inspection tools you need to see inside and inspect process and pressure components for cleanliness and mechanical damage; helping you assess condition and retrieve loose parts.

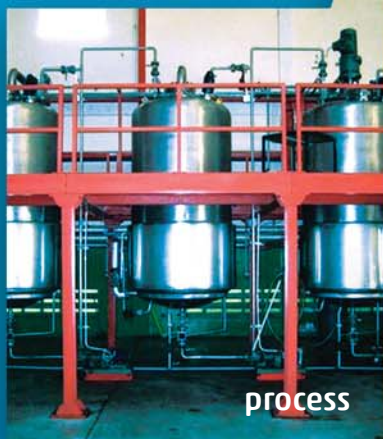

process

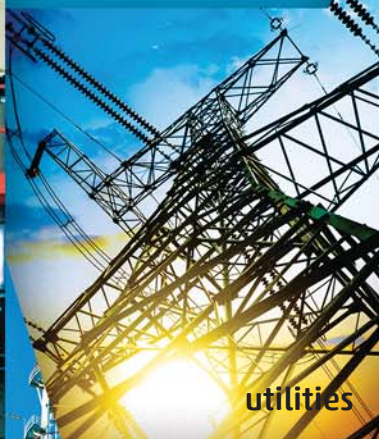

utilities



environmental



oil & gas



aerospace

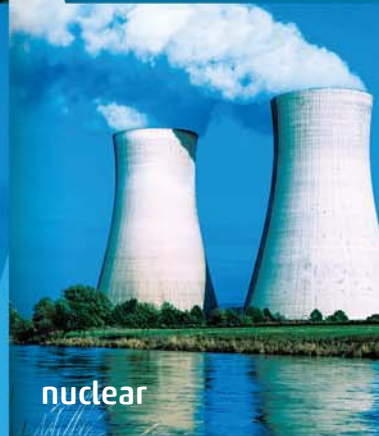

nuclear

innovation

At Sensor Networks, we combine new technologies with novel approaches to monitoring asset integrity, giving you advanced tools to keep your systems operating safely, productively and efficiently.



expertise

Drawing on more than 90 years of combined experience in visual inspection across a range of industrial sectors, our team takes the guesswork out of applications engineering. Trust us to bring the best technologies and techniques to bear on your inspection challenges.



reliability

More than thirty Fortune 500 companies already rely on our technology and team to gain better insight on their critical infrastructure.



PTZx

SNI's PTZx system includes everything you need to perform tank, vessel or large-area inspections of piping and facility infrastructure. This system, with 100' of cable, cable reel, monitor and digital recorder, weighs under 30 lbs. (13.6 kg) and can be carried with one hand. PTZx is rugged, reliable, waterproof, easy-to-use and the result of decades of RVI experience.

DVR monitor

- 5" TFT color LCD screen with sun shield
- Date/time stamp
- Stills captured as uncompressed BMP
- Video recorded as AVI
- Integrated mic with on/off
- SDHC card storage up to 32GB

control unit

- up to 45m cable reel (extendable up to 90m)
- Auto/manual focus
- Adjustable light intensity control
- Adjustable video brightness
- Camera position memory
- Image control (below, left to right: grid, reticle, negative image, image flip, freeze frame)



360-degree continuous rotation; 270-degree tilt



resin bed vessel internals

40x optical zoom



50' denim water tank

high-res CCD imager with sensitivity control for reflective surfaces

corrosion-resistant nickel-plated aluminum with stainless steel



vessel 12' dia. x 80' tall

submersible to 100'

LED lamps adjustable to 4000 lumens



mixing vanes in large glass-lined chemical vessel



auxiliary LED lights



configuration	lumens
integral light	2000
integral + auxiliary (x1)	3000
integral + auxiliary (x2)	4000

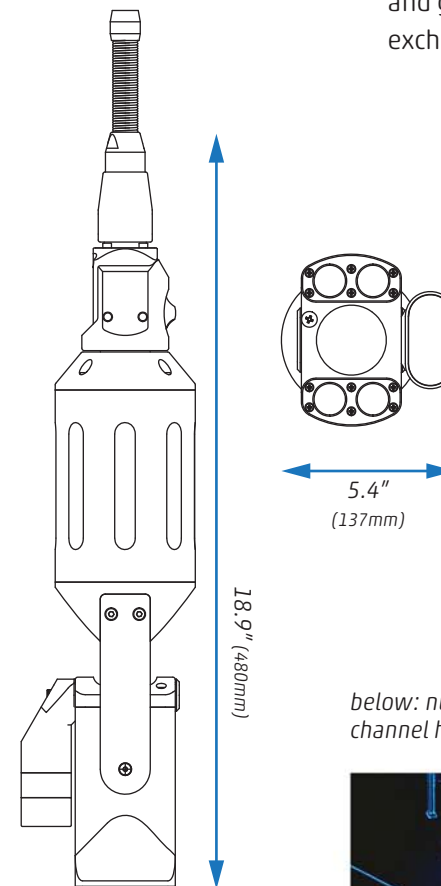

below: nuclear SG channel head



applications:

- **Nuclear Power:** Reactor pressure vessel, reactor cooling pumps, steam generator channel head, nozzle welds, fuel pool, fuel assembly, spent fuel, IWE/IWL exams.
- **Fossil Power:** FAC & MIC inspections, baffle plates, HP steam headers, tank and vessels.
- **Refining & Petrochemical:** Tray-towers, refractory- and glass-lined vessels, tanks, pipe racks, heat exchanger internals, baffle plates

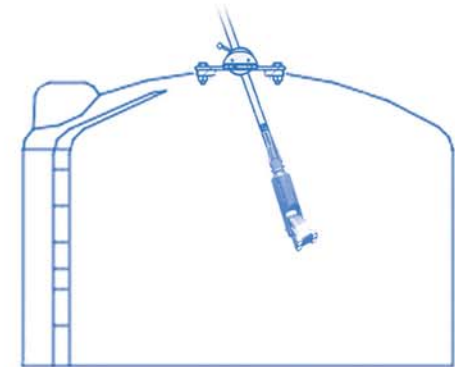

lowering pole

- carbon fiber tubing
- 6' (1.8m) length each
- connect two or more
- threaded stainless ends
- locking safety screw

pole camera adapter

- mounts to camera base with included screws
- threads onto pole
- stainless steel

tank flange mount

- mounts to flanged openings 4-24" (DN150-DN600)
- clamps pole to stabilize camera
- aluminum construction

lifting hoist ring

- mounts to pole end
- attaches to safety lanyard
- lifts pole and PTZ camera using an overhead crane



left: available optionally with a small, modular controller.

loose parts retrieval tooling



sampling of items retrieved



JAWS 2.0 with camera and illumination (actual size)

RGT (actual size)

jaws

left to right: sampling cups, curved serrated jaws, fork & tine, pliers, magnet, snare, hook

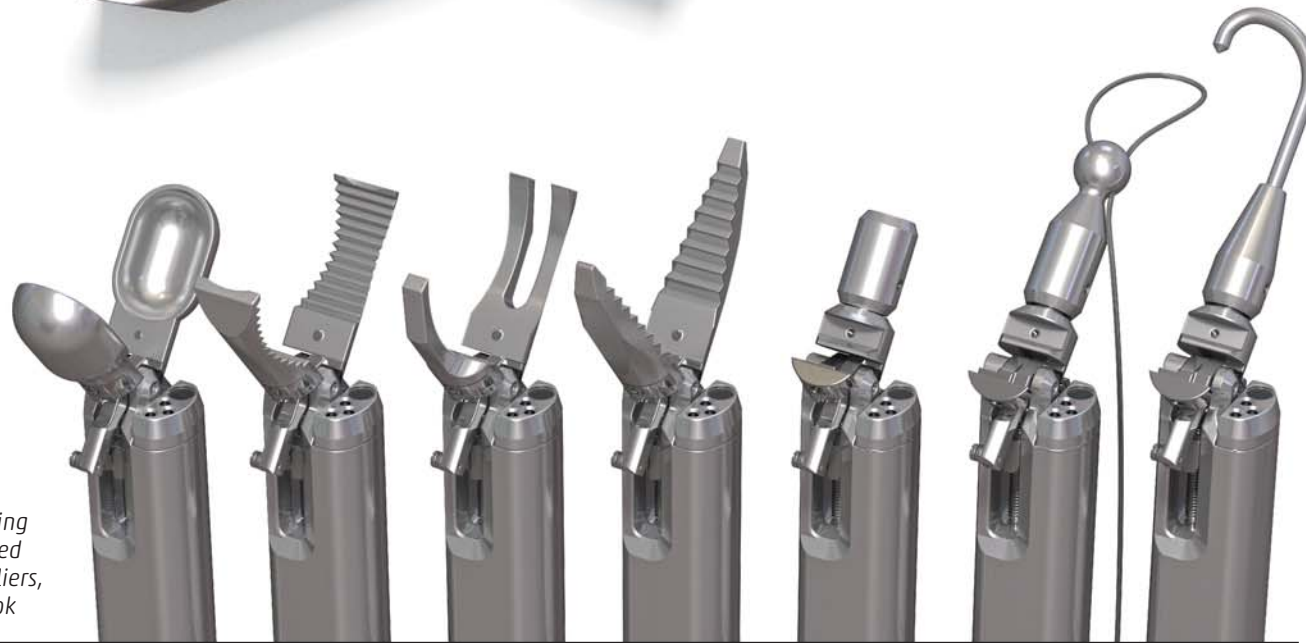

below: standard retrieval tool kit

delivery devices

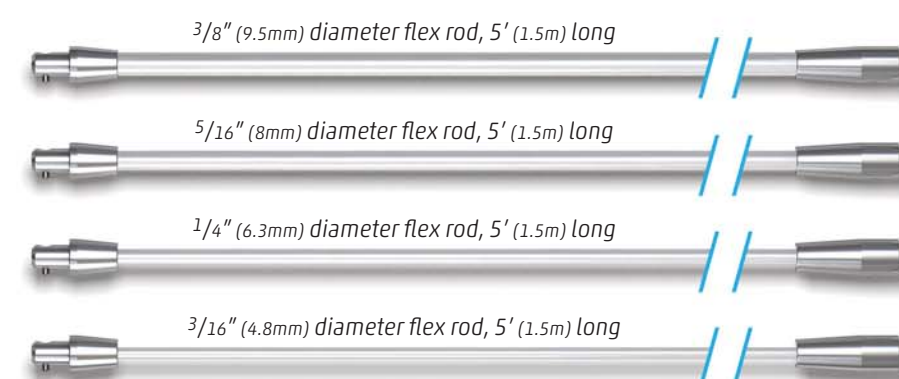
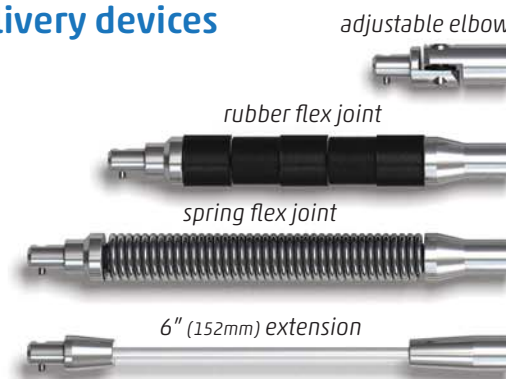

T-handle for rotational control

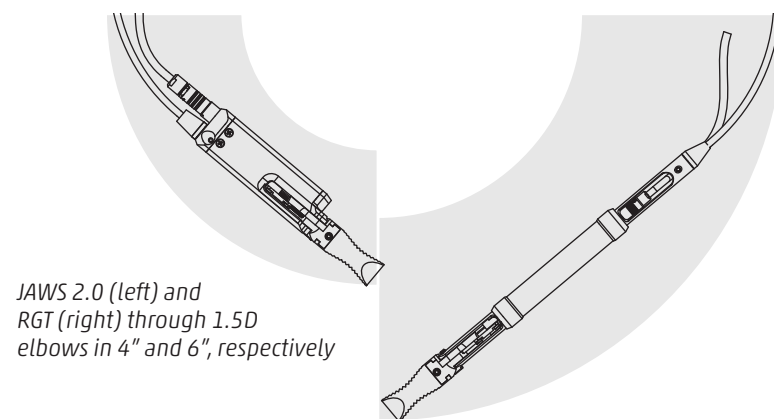

JAWS 2.0 (left) and RGT (right) through 1.5D elbows in 4" and 6", respectively

model PTZx

video

camera	Sony block camera
image sensor	1/4" Exview HAD CCD
effective pixels (NTSC/PAL)	480K/570K
video output	PAL/NTSC composite
optical zoom	40×
digital zoom	12×
total magnification	480×
sensitivity	0.6 lux
auto/manual focus	1 cm to ∞
min. foc. dist. (wide/tele)	0.4"/59.1"
hor. FOV (wide/tele)	60/1.6 deg
brightness adjustment	±10.5 dB

construction

camera head diameter	4.3" (109 mm)
dia. with auxiliary LED lights	6.2" (157 mm)
camera head length	18.9" (479 mm)
camera head weight	6.3 lb (3.0 kg)
material	nickel-plated aluminum, stainless
pressure rating	44 psi (3 bar)
cable reel length	150' (45m)
dims.	13.2×12.2×10.6" (330×310×270 mm)
base station weight	21 lb (9.5 kg)

lighting

built-in adjustable LEDs	0–2000 lumens
LED auxiliary lights	1000 lumens

controls

pan (left joystick left/right)	360 deg continuous
tilt (left joystick up/down)	±135 deg
pan/tilt speed	0–5 rpm
home (left joystick button)	resettable position
zoom (right joystick up/down)	
manual focus (right joystick left/right)	
auto focus (right joystick button)	
effects	grid, reticle, flip, negative, freeze

power

input	100–240 Vac, 4A, 50–60 Hz
-------	---------------------------

model RGT

description motorized retrieval tool

tool head

construction	stainless steel
diameter	0.875" (18 mm)
access required	1.0" (25 mm)
length	11.3" (287 mm)
push point connector	10 mm quick-disconnect
weight	0.7 lbs. (0.32 kg)
jaw opening	3.2" (81 mm)
jaw clamping force	25 to 55 lbs. at tip
end effectors	see below*

cable

cable material	polyurethane
cable dia.	3/16" (4.5 mm)
cable length	50' (15 m) with extensions

power supply

type	Lithium Ion rechargeable
size	7.0×4.8×2.7"
weight	1 lb. (0.452 kg)
features	battery gage

* Tool comes standard with one flat serrated jaw.

Options include a curved serrated, fork & tine, needle-nose pliers, sampling cups, hooks and manual tool adapter.

model JAWS 2.0™

description motorized retrieval tool with integral camera and LED lights

tool head

construction	stainless steel
diameter	1.3" (34 mm)
access required	1.5" (38 mm)
length	8.2" (207 mm)
push point connector	10 mm quick-disconnect
weight	1.2 lbs. (0.54 kg)
jaw opening	3.2" (81 mm)
jaw clamping force	25 to 55 lbs. at tip
end effectors	see below*

cable

cable material	TPE
cable dia.	1/4" (6 mm)
cable length	50' (15 m) with extensions

power supply

type	10 each AA batteries
size	7.0×4.7×2"
weight	1.7 lbs. (0.77 kg)
features	color 3.5" display, analog video output, battery gage, grip strength indicator

camera

camera	1/5" color CMOS (640x480 pixels) 30 FPS, 6.0 lux sensitivity
viewing angle	77° hor., 60° vert., 92° diag.
lighting	3 long-life LEDs, total 10 lumens



Inspection, Testing & Asset-Integrity Solutions

176-500 Technology Dr. • Boalsburg, PA 16827
(814) 466-7207 • offices in Houston, Hong Kong, Beijing

www.sensornetworksinc.com

Sensor Networks is a registered trademark of Sensor Networks, Inc. ©2017. All rights reserved.
PTZx™ and JAWS 2.0™ are Trademarks of Sensor Networks, Inc. JAWS 2.0 design is patent pending.

Z-CHECK
CORPORATION

35560 Grand River Ave, #420
Farmington Hills, MI 48335
P: 248-676-1007 / E: sales@z-checkcorp.com
Website: www.z-checkcorp.com