



HD-PTZx™

High-Definition Visual Inspection. Pan. Tilt. Zoom.

HDTV Remote Visual Inspection Tool

Sensor Networks, Inc (SNI) introduces a new Full High-Definition (HDTV) version of its field-hardened, rugged, waterproof and reliable Pan-Tilt-Zoom industrial video inspection camera system.

With cable lengths up to 500 feet, and available with either a small CCU or an integral cable reel CCU, HD-PTZx™ also features 1080p video resolution that is ~6 times better than that of conventional CCTV video. Full HD image resolution provides for practical digital zooming without pixilation.

- Aircraft engine assembly and test cells
- Large-diameter pipes, tanks & vessels
- Nuclear reactor vessel, nozzles and internals
- Nuclear fuel, spent-fuel pools, refueling operations
- Steam generator primary-side and secondary-side inspections
- Plastic-, glass-, refractory-lined, and stainless-clad vessels
- Catalyst vessels and tray towers



Unrivaled Inspection

Integrated System



Modular System

Joystick-controlled, variable-speed 270- or 244-deg tilt angle & 360-deg continuous pan rotation

Corrosion-resistant, nickel-plated aluminum with stainless-steel construction

Submersible to 100 ft (30m) of water

Integral dimmable white LEDs & optional auxiliary LED modules

30x or 10x optical zoom lens

Full-HD (1920x1080p) camera with light sensitivity control for reflective surfaces

Optional sunlight-viewable 7-inch display or display with recorder (shown)

HD-PTZx43 specs

HD-PTZx35 specs

video

optical/digital zoom	30X / 12X
effective pixels	2.13 MP
sensitivity	0.5 lux
HFOV	W 59° / T 2.1°
minimum focus	W 0.1m / T 1.2m

controls

pan/tilt	360° continuous / ±135°
zoom/focus	variable speed
light sensitivity	±7 steps

lighting

integral LEDs dimmable	2000 lumens
auxiliary LED modules	1000 lumens (2)

lighting

head weight	6.4 lb (2.9 Kg)
system weight (reel & 150 ft cable)	29 lb (13.2 Kg)

video

optical/digital zoom	10X / 12X
effective pixels	2.13 MP
sensitivity	0.5 lux
HFOV	W 54° / T 4.9°
minimum focus	W 0.01m / T 1.0m

controls

pan/tilt	360° continuous / ±122°
zoom/focus	variable speed
light sensitivity	±7 steps

lighting

integral LEDs dimmable	2000 lumens
auxiliary LED modules	1000 lumens (2)

lighting

head weight	6.3 lb (2.8 Kg)
system weight (reel & 150 ft cable)	28.9 lb (13.1 Kg)

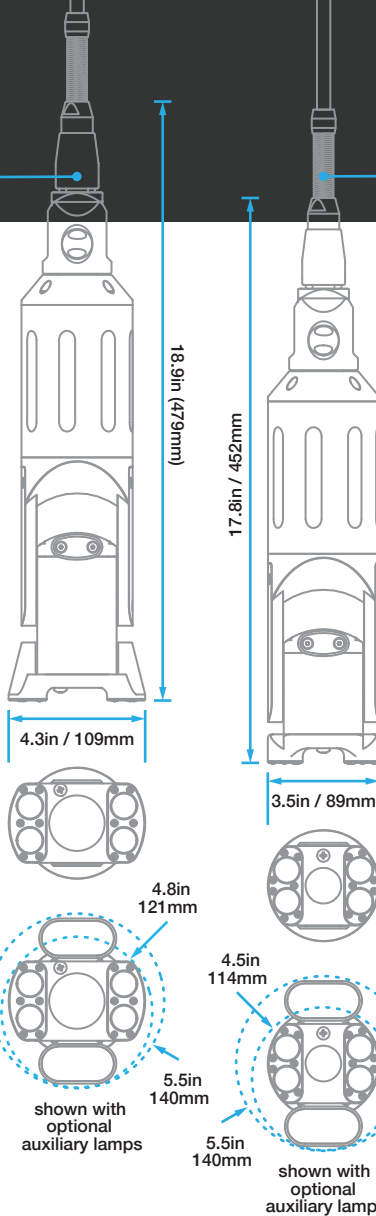

HD | 1920x1080

x4

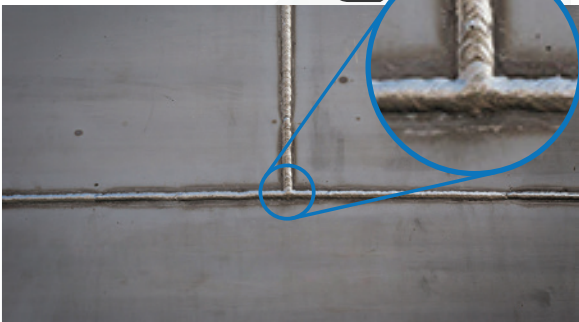

SD | 720x480

x4

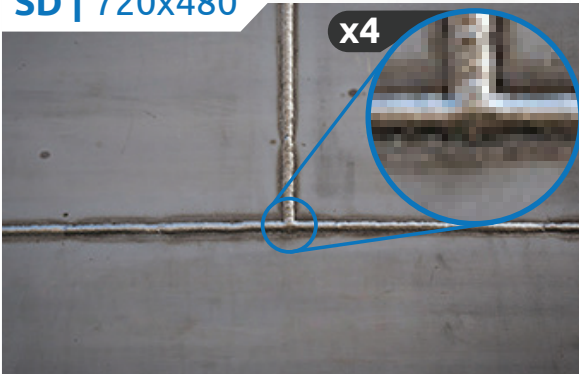

environment

temperature	14°F (-10°C) to 120°F (49°C)
pressure rating	44 psi / 100 ft (30 m) depth
purgeable	up to 10 psi (.7 bar)
cable length	up to 500 ft (150m)
material	nickel-plated aluminum, stainless steel
portability	single case, one-hand carry
radiation (1.25MeV)	TBD*

* Contact us for our radiation test data.

HDTV - 1080p (1920 x 1080)

HDTV - 720p (1280 x 720)

NTSC DVD
(720 x 480)

additional accessories

- auxiliary spot light
- auxiliary flood light
- tank flange mount
- lowering pole
- pole camera adapter
- shipping cases

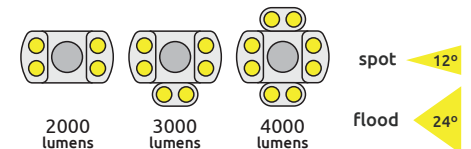

system features

image overlay with keyboard	time, date, position temperature, pressure humidity, image title
image effects	flip, freeze, long exposure digital zoom
home position	saved pan-tilt-zoom position

interface

video	2 HDMI Ports
accessory power	12 VDC
power	100-240 VAC 4 amp, 50/60 Hz