

Automatic Brinell

Direct Reading Brinell Hardness Testing System

Series 9000N Version 8.1
OPERATION MANUAL

Contents

i. Routine Inspection and Emergency Return Checklist	vii
ii. Brief Summary of Keypad Functions.	ix
iii. PART NAME/LOCATIONS	x
1. GENERAL INFORMATION.	1-1
1.1 Automatic Brinell Test Methods.	1-1
1.2 Machine Description	1-1
1.2.1 Basic Configuration	1-1
1.2.2 Test Head	1-2
1.2.3 Electronic System	1-3
1.2.4 Test Stand	1-3
1.2.5 Hydraulic Power Supply and Cylinder	1-3
2. OPERATION.	2-1
2.1 Example of Standard Test Operation	2-1
2.2 Test Head Retraction	2-2
2.3 Fixturing	2-2
2.3.1 Positioning.	2-2
2.3.2 Orientation	2-2
2.3.3 Specimen Stability	2-3
2.3.4 Accuracy.	2-3
2.3.5 Compressible Test Samples	2-3
2.4 Keypad Operation	2-4
2.4.1 List of Key Functions	2-4
2.4.2 Security Code Procedure	2-5
2.4.3 Scale Selection Function.	2-7
2.4.4 Calibration (Cal) Key Function.	2-8
2.4.5 0-Set Key Function	2-9
2.4.6 Tolerance (TOL) Function	2-10
2.4.7 Statistics (STAT) Functions	2-11
2.4.8 Print Functions	2-14
2.4.9 Mode Key Functions	2-17
2.5 Digital Readout Codes	2-20
2.5.1 Routine Inspection and Emergency Return Checklist.	2-21

3. SPECIFICATIONS AND SERVICING PROCEDURES	3-1
3.1 Environmental	3-1
3.2 Electronic Output Specifications	3-1
3.3 General Description	3-2
3.4 Tester Components	3-3
3.5 Routine Procedures	3-4
3.5.1 Indenters and Shroud Removal/Install	3-4
3.5.2 Test Head Removal and Mounting	3-5
3.6 Hydraulic system	3-6
3.7 Load and Penetration Depth Gauging	3-7
3.7.1 Load Cell.	3-7
3.7.2 Safety Device Checking and Adjustment	3-8
3.7.3 LS2 - Preload Switch	3-8
3.7.4 Transducer.	3-9
3.7.5 Load Calibration.	3-10
3.7.6 Electronic Adjustments	3-11
3.8 Electric & Electronic, Power Requirements & Outputs	3-12
3.8.1 Power Requirements for the Electronic Control Console	3-12
3.8.2 Power Requirements for the Hydraulic Unit.	3-12
3.8.3 Electronic Output.	3-12
3.8.4 Electronic Box Diagram.	3-13
3.8.5 Electric Cables and Pin Assignments	3-50
4. TROUBLESHOOTING.	4-1
5. SERVICE AND SHIPPING	5-1
6. ONE YEAR LIMITED WARRANTY	6-1

i. Routine Inspection and Emergency Return Checklist

(See maintenance Section for Fuller Description)

Routine inspections are very important to perform on a daily basis, or if the machine is used less frequently, whenever it is turned on.

Emergency Return Checklist Items are to be performed whenever the test head retracts from using the Emergency Return Switch after the load has begun to be applied or when the test head retracts for an unknown reason.

Routine Inspection and Emergency Return Checklist

- Check test head centering
- Check for tightness on all screws in the head and frame.
- Check safety device with cardboard test.
- Check calibration
- Check indenter shroud and indenter for deformation.
- Check anvil and fixtures for tightness and deformation.

Additional Maintenance Checklist Items

- Check hydraulic for clean filter
- Check hydraulic for proper pressure during test load
- Check hydraulic for proper pressure during UP cycle of test head
- Check hydraulic cylinder for dirt and scratches
- Check hydraulic cylinder for leaking



7	8	9	
4	5	6	START
1	2	3	0

	MODE	PRINT
STAT	TOL	CAL
∅ SET	CONV	ENTER

ROUTINE FUNCTIONS		
YES	-Acknowledges selection on display -Print result when Print "On Demand" is selected -Convert minimum thickness value: inches / metric	
NO	-Returns to "READY" for test -Advance to next selection	
YES	SCALE SELECT	NO

Keypad

ii. Brief Summary of Keypad Functions

TOL:	- For viewing or modifying tolerance values
SCALE SELECT:	- For changing hardness scales or set-up files each of which can contain different calibration and tolerance settings
YES:	- Acknowledge questions on display - Prints out results when Print/On Demand function is selected - Converts minimum thickness readings between inches and millimeters
NO:	- Negates selection on display and restores "READY" - Advances sequential functions to next selection
STAT:	- Clear Last Result function, - Clear All Results function - Change Sequence Number function - Change Lot Number function, - View Statistics on LED display - View statistics - Split Memory (Optional)
ENTER:	- Enters numeric values in memory
PRINT:	- Print Totals of all Statistics - Print Graph (histogram) - Print History of all results in memory - X-Bar & R Chart - Results/Values Only - Print On Demand the results when operator prompts the tester - Print Off - Print Trace of all messages and results appearing on the display - Set Baud - Set Codes
MODE:	- Timed load - Diameter function (Brinell) - Minimum Thickness function - Transducer Check - Averaging functions - Diameter Results - Disable History - Set Clock (Optional)
CAL:	- Calculate Hardness - Calculate Displacement - Clear Hardness Calculation - Clear Displacement - Factory set
0 SET:	- Fast Adjustment of the depth/Brinell curve for a previously evaluated material
CONV:	- Changes Display to Self Test mode

NOTE: OTHER FUNCTIONS MAY APPEAR IF OPTIONAL SOFTWARE FUNCTIONS ARE USED. REFER TO THE APPENDIX AT THE BACK OF THE MANUAL.

iii. PART NAME/LOCATIONS

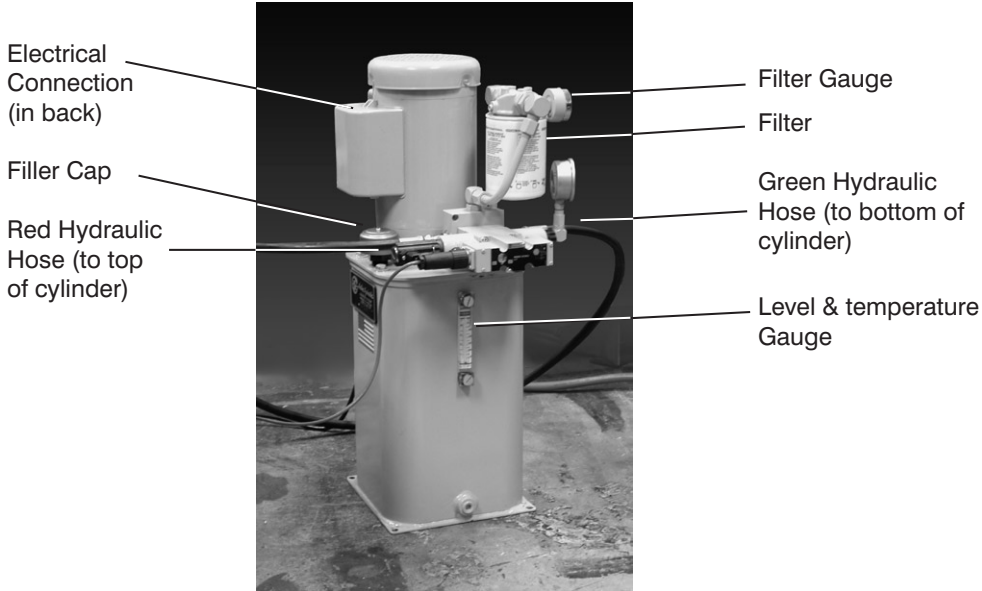

1.GENERAL INFORMATION

1.1 Automatic Brinell Test Methods

The Automatic Brinell System makes a Brinell impression in conformance with the standard method for Brinell testing as described in ASTM E10. The impression made by the Automatic Brinell may be measured optically by an operator to attain the Brinell Hardness Number. The Automatic Brinell tester, however, instead of measuring the width of the impression with a scope, automatically measures the depth of the indentation. (The depth measurement method is described in ASTM E103.) This technique provides the advantages of greater speed and reduced operator influence on the test results. Since no optical measurements are made, different operators will consistently provide exceptionally repeatable test results.

Like the Rockwell hardness test method, this depth measurement is calculated based on the difference in penetration depth between a preload and a major load position. The tester applies a preload, zeros the measurement, applies the full load, returns to the preload setting and makes its depth reading. The zeroing function is automatically done both mechanically and electronically.

For a given material this depth measurement has been established to be linearly related to the width measurement, but this relationship may change from one material to another. Some examples of specific factors that can offset this relationship are the elastic recovery of the material that causes the bottom of the impression to compress to different depths. Also, the ridge of material that forms around the lip of the impression may be higher for some materials.

In order to compensate for these factors, the Automatic Brinell can be programmed to adjust the readout so it accurately reflects the actual linear relationship between the depth and the width of the impression. This relationship is easily established by making tests and comparing the automatic readouts with optical measurements of the same impressions. Then the tester is told to offset its own calculation of the results by a certain value so that it will thereafter read accurately on that material. Once the machine has been set up for a material, it can easily be changed to a different offset for another material or changed back again in a few seconds. The tester can then be verified for accuracy at any time by making an optical reading of the diameter of the impression.

1.2 Machine Description

1.2.1 Basic Configuration

The tester consists of a number of components as shown in the illustrations in the Specifications Section. Insofar as possible each component is modular and designed for easy maintenance or servicing. Principal components such as the test head and electronic readout box, as well as sub- assemblies, are easily removed or replaced in minutes without any requirements for special tools or skills. The hydraulics are simple in design and standard in manufacture so that they can be serviced by average shop maintenance personnel. All electrical components have connectors on at least one side so they can be quickly disconnected, and external wiring cables are keyed so that they can only be hooked up properly.

1.2.2 Test Head

The main gauging components of the Automatic Brinell are located in the test head. The head incorporates load controlling elements, a measuring system, and other devices to ensure safe operation and constant test parameters. The load controlling element inside the head consists of a high accuracy load cell that accurately detects the load being applied. All load and measurement settings are easily adjusted. (Refer to the maintenance section.) The depth sensing element is an LVDT.

Other sensing devices have been incorporated into the test head to detect certain conditions: soft materials (e.g. operators' hands), unstable or non-level test surfaces, or the absence of a test specimen. When triggered these devices initiate an automatic return of the test head. Also, some conditions of improper start positioning can be detected. In this case, the tester may prevent itself from making a test, if the part is too far out of level.

The Automatic Brinell System uses a special test surface reference device -- a floating nosepiece or shroud that surrounds the indenter and which references the surface of the specimen. This feature allows the tester to retain accurate readings even as the tester frame or test sample deforms during load, because it maintains contact to and reference with the original preload position during the test cycle. Another advantage to the nosepiece is that it tilts to allow testing on surfaces that are out of level by up to two degrees. This means that castings with a normal draft angle may be tested with accurate results. Also, normal dimensional variation on the parts will not adversely affect the results. Standard universal or customized fixturing may be required, however to provide good lateral or rotational stability on some parts that fall outside the parameters for stable and accurate test specimens. (Please refer to the Fixturing Section.)

1.2.3 Electronic System

All the electronics are run off a 120V line separate from the power supply to the hydraulics. This line should be isolated so that irregularities in supply do not affect the electronics.

1.2.4 Test Stand

The stand has a C frame that carries the hydraulic cylinder which applies the load.

1.2.5 Hydraulic Power Supply and Cylinder

The Automatic Brinell System has a hydraulic system to drive the test head through a 4" stroke. The power of the cylinder is translated into a load.

2. OPERATION

(Please refer to the illustration in the specification section for actual part locations)

2.1 Example of Standard Test Operation

- 1) Turn on power to hydraulics. Turn the OFF/ON switch to the ON position (at back of electronic box). The digital readout will say:



SELF TEST V XX.X

This display will remain on for a short time while performing routine checks of internal functions and the transducer. After all functions have been verified for proper operation the tester will enter the test mode and the display will show a ready status:

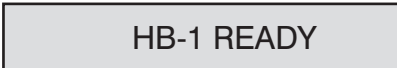

HB-1 READY

This display would indicate that the tester was in the HB1 scale and the tester was ready to start performing tests. The scale will be set on the last scale selected even if the unit was turned off since that selection.

- 2) Properly position a test specimen on the anvil and adjust the elevating screw so the top surface of the specimen is within reach of the stroke of the test head and is perpendicular to the test surface.

(IMPORTANT: Please refer to the section for Fixturing to insure that the test specimen is in a stable position for testing.)

- 3) Depress the foot pedal (or initiate start switch) and keep it depressed for at least 0.5 seconds. The test head will begin to move downward. If the foot pedal is released at any time before full load is reached, the tester will stop and remain at the same position until the pedal is activated again and full load is reached. (This allows the operator to "jog" the test head down close to the test sample prior to testing to allow for optimum test positioning.)

(NOTE: The transducer detects the difference in depth of penetration between the indenter nosepiece which is pressed against the test surface and the indenter which has made an indentation into the surface. This gives the depth measurement which is then translated into a Brinell Hardness Number or equivalent diameter measurement by the programming in the console.)

After reaching the full load is reached, the test head remains in this position with the full load for the selected time-at-load, then automatically retracts. At this time the hardness value is displayed. Typically the display would appear like this:

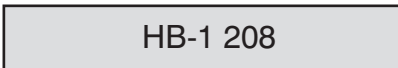

HB-1 208

This display would indicate that the tester was set in the first Brinell scale setup file and the Brinell Hardness Number was 208.

The display may show a tolerance indicator, (OK, LO, HI). Each scale setup file can have its own tolerance settings. Refer to TOL (tolerance) key functions.

When the test head returns to the “home” position with the hydraulics retracted, the machine is ready for another test. Each succeeding test is performed simply by placing the part in position, depressing the foot pedal until the dial indicates that full load has been applied, and reading out the hardness result from the digital display.

PLEASE NOTE: In order to test the tester must indicate a ready status by either the “READY” readout on the display or a test result from the preceding test.

2.2 Test Head Retraction

If at any time during the cycle, the Emergency Return button (customer supplied) is pressed or the tester senses a bad test parameter such as a soft material (like the operator’s hand) the test head immediately retracts to the home position.

(CAUTION Regarding the safety switch to retract the test head: if the operator has his hand under the indenter during the load, the safety switch will not prevent injury. It may lessen the degree of injury.

2.3 Fixturing

Fixturing plays an important part in stable accurate automatic Brinell testing. Different functions that fixturing performs are:

2.3.1 Positioning

In a high production testing environment, it is often important to automatically index the proper test position with a fixture so the operator does not have to take the time or use judgement to align each part. If testing the the edge of a specimen, positioning changes can dramaticall affect the hardness reading if the test is too close to the edge.

2.3.2 Orientation

The Automatic Brinell nodepiece is designed to tilt slightly to enable accurate testing on slightly tilted test surfaces.

If a part has a draft angle of MORE than two degrees, or has irregularities like a parting line and flash on the underside of the test specimen that causes the part to tilt more than two degrees, or has a shape that won’t support the specimen, it must be supported to orient the top surface so that it is close to perpendicular to the axis of indentation.

2.3.3 Specimen Stability

Some part configurations present an inherently unstable shape for supporting a load. Some common examples are shapes with curves in more than one direction like a football shape or a nose cone. Other parts that are inherently unstable are long, narrow parts to be tested on the end. Small amounts of angle on the supporting end can cause the specimen to lean over at a substantial angle while the load is applied. These types of parts should be supported or referenced at the sides so they will not be able to lean.

2.3.4 Accuracy

Sometimes irregularities such as large flashlines can cause a specimen to rock slightly as it settles in under load. This change in orientation changes the indenter to shroud relationship after the preload has been zeroed. This can cause inaccurate calculation of the depth of penetration by the tester even though the final indentation gives an accurate result.

2.3.5 Compressible Test Samples

Some parts, such as cylindrical shapes similar to a proving ring, can compress under the load and, in effect, store the force of the test load. If the part should break or slip under load, the large load of the test can cause forceful ejection of pieces or the entire part presenting a dangerous situation to the operator.

CAUTION

- 1) Do not attempt to test parts that will move under load. Injury may occur.
- 2) Train operators to detect parts that cannot be tested.
- 3) Verify proper functioning of all emergency switches on a regular basis.

For questions on fixturing please call Newage Testing Instruments.

2.4 Keypad Operation

2.4.1 List of Key Functions

Each key on the keypad has a number of functions. A brief list of these functions is as follows:

- TOL: - For viewing or modifying tolerance values
- SCALE SELECT: - For changing hardness scales or set-up files each of which can contain different calibration and tolerance settings
- YES: - Acknowledge questions on display
- Prints out results when Print/On Demand function is selected
- Converts minimum thickness readings between inches and millimeters
- NO: - Negates selection on display and restores "READY"
- Advances sequential functions to next selection
- STAT: - Clear Last Result function,
- Clear All Results function
- Change Sequence Number function
- Change Lot Number function,
- View Statistics on LED display
- View statistics
- Split Memory (Optional)
- ENTER: - Enters numeric values in memory
- PRINT: - Print Totals of all Statistics
- Print Graph (histogram)
- Print History of all results in memory
- X-Bar & R Chart
- Results/Values Only
- Print On Demand the results when operator prompts the tester
- Print Off
- Print Trace of all messages and results appearing on the display
- Set Baud
- Set Codes
- MODE: - Timed load
- Diameter function (Brinell)
- Minimum Thickness function
- Transducer Check
- Averaging functions
- Diameter Results
- Disable History
- Set Clock (Optional)
- CAL: - Calculate Hardness
- Calculate Displacement
- Clear Hardness Calculation
- Clear Displacement
- Factory set
- 0 SET: - Fast Adjustment of the depth/Brinell curve for a previously evaluated material
- CONV: - Changes Display to Self Test mode

NOTE: OTHER FUNCTIONS MAY APPEAR IF OPTIONAL SOFTWARE FUNCTIONS ARE USED. REFER TO THE APPENDIX AT THE BACK OF THE MANUAL

2.4.2 Security Code Procedure

Many of the system functions remain inoperable unless a code number is entered and certain function keys are pressed. This procedure “enables” these keys and key functions. This security feature is designed to prevent unauthorized personnel from changing the test inputs and outputs.

The following keys are affected by the security code:

SCALE SELECT	not accessible without code
0 SET	may be viewed but not changed without code
CAL	not accessible without code
TOL	may be viewed but not changed without code
STAT	access for viewing only without code
PRINT	partial access for operation without code
MODE	Not accessible without code

The following routine will enable any of the function keys desired:

1. Pressing the CONV. key while the machine displays “READY” or is first turned on causes the following message to appear on the display:

SELF TEST V X.X

2. Within a five seconds after this display appears the operator must begin to input the security code number. If the operator fails to begin to enter the security code procedure with-in the time allotted, the system will revert back to the test mode. (Once the first key is pressed the operator will have about 60 seconds more to complete the procedure.) As each code number is entered, the letters in the display disappear from the left as confirmation.

Keypad

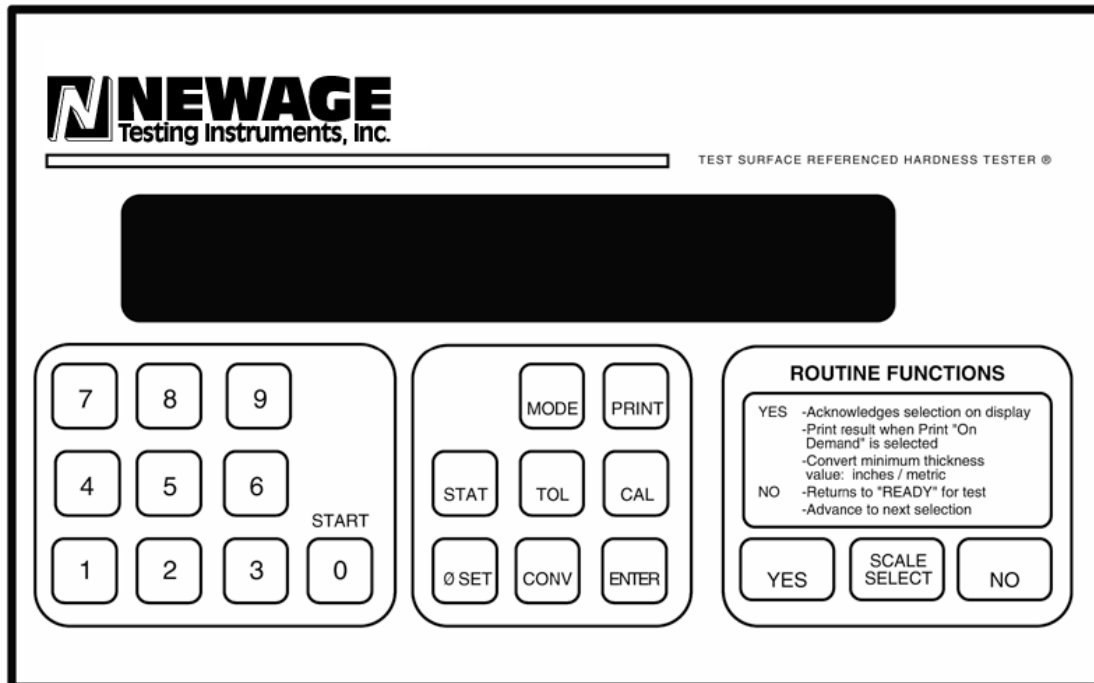

3. Press the function keys controlled by the code that are to be enabled. Any combination of function keys may be enabled so that the operator may have partial or complete access to the machine capabilities. (Do -not press numeric keys or YES, NO, or CONV keys.)
4. Press the ENTER key. This completes the security procedure and the system returns to the test mode.

PLEASE NOTE: The keys will remain enabled or disabled, as they were most recently set up, even after the system has been switched off.

2.4.3 Scale Selection Function

This tester performs all its testing in the HB30 scale (Brinell Hardness with a 10mm carbide ball and 3000 kg. load or optionally another load) . However, depending on the system, this same scale may be stored in the electronic memory - typically 1- 3 times. Each scale has a different scale number in order to store different test parameters - like tolerances settings.

There is no difference between any of these scale/files. They are all set up initially the same way so the operator can tailor each of them to his needs. Each of the scales is set up by default with only the basic information necessary to get a Brinell result. This allows each of the scales to be set up, if desired, with other test parameters like high and low tolerances or a zero displacement (calibration) value. Once these parameters have been set up, the operator can quickly switch scales to test various materials or parts without entering new parameters.

A few thousand test results may be stored in a scale/file before it becomes full. If an E-17 or Memory Full, message appears the “Clear All” under the STAT key functions should be used.

IMPORTANT: When the operator changes scales, all the test results stored in the system memory for the last scale used will be forgotten, unless the Split Memory Option is in use.

The hardness scale is always displayed while the tester is in the test mode. Typical displays when the tester is ready to perform a test might be:

or

These displays would indicate “READY” to start testing in the first Brinell scale or that it had performed a test with a Brinell value of HB 218, and was ready to perform another test.

OPERATION WITH SECURITY CODE ACCESS:

Pressing the SCALE SELECT key (when enabled with the security code), will make the display read:

Pressing YES will enter (select) the HB-1 scale and return the tester to the test mode.

Pressing NO will stop the scale selection function and return the tester to the test mode in the last scale that was actually entered.

Pressing the SCALE SELECT key again will cause the readout to display the next scale in sequence. If the operator continues to hold the SCALE SELECT key down, the tester will continue to display each scale in sequence at one second intervals. The operator may also press the SCALE SELECT key repeatedly to view the scales in sequence. At any point a scale may be selected by pressing the YES key. The operator may also choose to skip changing scales by pressing the NO key.

OPERATION WITHOUT SECURITY CODE ACCESS:

The scale may not be changed without security code clearance

2.4.4 Calibration (Cal) Key Function

The Calibration key is normally used to control factory set software functions and is not normally accessible. There are 3 parameters involved in the calibration which are important to control:

- 1) Electronic Calibration for different materials (refer to 0-Set Key Function).
- 2) Transducer Calibration (refer to Transducer Section)
- 3) Load Calibration (refer to Load Calibration Section)

2.4.5 0-Set Key Function

The Zero Displacement function is designed for precise calibration on a particular material or for parts of the same material but with a significant difference of hardness (normally 40 pts). This function should be used when testing on any long test nuns or other applications where accuracy is most important. Once the number is set, it should be good for that part whenever it is run. (If there is a large range of hardness between different parts of the same material, a single zero displacement value may not work for all the parts.)

With the machine at original calibration (no “*” on display), the factory-set zero displacement value is 860. (DPTH = 100.0).

1. Number and test 5-10 parts and record the Brinell numbers test results from the tester.
2. Optically read the impressions and record the Brinell values next to the corresponding Automatic Brinell values. Make the readings as accurate as possible.
3. Average the 10 values from each series of readings (optical scope and automatic Brinell) and calculate the difference,
4. If the automatic values have an average value lower than the average optical readings, add the difference to the zero displacement value and enter that number into zero displacement. If it's higher, subtract from the zero displacement. Press 0 SET key, key is the new number, press ENTER key, enter security code (see calibration certificate).
5. Also note the range of values for each series of readings. They should be close to the same range. After the zero displacement is adjusted the LED display will show a “*” at the right side indicating that the machine has been calibrated.

This procedure reduces the inherent variation in optical measurements of the width of the impression. Subsequent readings from the tester should match the optical readings, within approximately +/- 0.05mm.

Technical Note:

The Brinell Hardness Scale may be graphed as a curve relating width of an indenter impression to the hardness of test materials. The depth-of-indentation curve is linearly related to the diameter-of-indentation curve, but in practice this curve may have to be adjusted to account for the individual characteristics of a specific material. Examples of factors that can cause an offset are anisotropic elastic properties or plastic deformation causing differing ridge effects around the lip of the impression or differing amounts of elastic recovery at the bottom of an impression. The calibration function allows the curve that is preset in the computer memory to be adapted for different materials so that the automatic depth measurement curve will equate closely with the optical width measurement curve.

2.4.6 Tolerance (TOL) Function

The Tolerance function allows the operator to view or set high and low tolerance limits in only one of the HB scales for acceptable hardness results.

Each scale on file can have its own tolerance setting. When tolerances are setup, hardness values will be displayed with “HI”, “LO”, or “OK” indicators. Indicators on the display flash on and off.

OPERATION WITHOUT SECURITY CODE ACCESS

Pressing the TOL key, when the Tolerance function A-Mt enabled, will cause the display to show the high and low tolerances. For example:

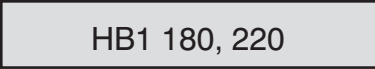

HB1 180, 220

This display would indicate a high tolerance limit of 220 and a low tolerance of 180 for the HB-1 scale. This message will remain on the display until either the NO key is pressed or until another function is selected.

OPERATION WITH SECURITY CODE ACCESS

1) If the “Brinell Result” mode function is selected, pressing the TOL key, when the Tolerance function will cause the display to show the scale and the low tolerance setting. For example:



HB1 LOW = 180

(Pressing NO or another function button after pressing the TOL key will cause the system to return to the test mode without changing the low setting.)

2) Pressing numeric keys and the ENTER key will cause a new low tolerance value to replace the old one and the display to show the current high tolerance value (see next example). (Pressing the ENTER key alone without changing the low tolerance value will also cause the tester to display the high tolerance value.)



HB1 HIGH = 220

This value may or may not be changed in the same manner as the low tolerance value. When the ENTER key is pressed the system will return to the test mode.

To eliminate the Tolerance function display, set the high and low tolerance values at “0” and “999”. No indication of HI, LO, or OK will appear.

PLEASE NOTE: If the tolerances are changed in the middle of a lot, the printout and statistical calculations will use the final tolerance values for the entire lot.

2.4.7 Statistics (STAT) Functions

The STAT key functions control the test information stored in the system memory.

There are five (or optionally 6) STAT functions: Clear Last, Clear All, Sequence Number, Lot Number and Statistics (optionally Split Memory). These functions appear in sequence when the operator presses the NO key as each appears on the display unless the key does not have security code access

OPERATION WITH SECURITY CODE ACCESS

CLEAR LAST

Pressing the HISTORY DATA key will cause the display to read:



HB1 CLEAR LAST?

>>>) Pressing YES will remove the last hardness reading from the history data and the system will return to the test mode. This procedure can be repeated to remove additional readings. If results are being printed, the last sequence # from the cleared test will be repeated.

CLEAR ALL

Pressing YES will clear all the hardness results from the memory for a particular scale/file and return the system to the test mode.

PLEASE NOTE: The Clear All function is automatically performed each time the calibrate function is performed or the zero displacement number is changed.

SEQUENCE NUMBER

Pressing YES will select the SEQUENCE NUMBER function. The sequence numbers are used to identify individual tests. Each time a test is performed the sequence number is increased by a value of one to a maximum of 65535. The sequence number will appear on the test results printout. When the Sequence Number function is selected by pressing YES the display might read:

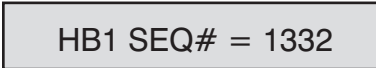

HB1 SEQ# = 1332

(The “#” symbol as it actually appears on the display in three parallel lines, №.) This display shows the current scale is HB-1 and the last sequence number is 1332. If the HISTORY DATA key is enabled and the test result memory is cleared (through the Clear-All function), the operator may select and enter a new sequence number. To start a sequence at a given number, he enters the prior sequence number. For example, to start the sequence at “1” the operator must enter “0”.

If the NO button or another function button is pressed before a new number is entered, the system will return to the test mode or initiate the new function without changing the sequence number. After a number is selected and entered the system will return to the test mode.

LOT NUMBER

Pressing YES will select the LOT NUMBER function. The Lot Number function is used to identify tests performed on particular groups of materials and will appear on the printout. The lot number function allows the operator to change the lot number. When this function is selected the display might read:

HB-1 LOT 5858

This display would indicate the system is in the HB1 scale and that the lot number is 5858. The operator may now select and enter a new number if the history data function is enabled. When YES is pressed the display will clear to make room for a 16 digit entry. The system will return to the test mode. If the NO button is pressed the system will return to the test mode without changing the lot number.

STATISTICS

Pressing YES will enable the operator to view the statistics. This function displays the mean and standard deviation of the readings. All the readings since the last Scale Select, Clear All, Calibration, or Zero Displacement function were performed will be included in these calculations. A maximum of 3500 values can be stored for statistical analysis. The statistics display might read:

HB-1 207.2, 2.443

The first number would indicate an average value of 207.2 and the second number would indicate a standard deviation of 2.433. The calculation of the deviation is based on the Brinell Hardness Numbers, not the diameter measurement. These values will remain on display until the NO button or another function button is pressed.

SPLIT MEMORY (OPTIONAL)

This feature allows the available memory to be divided into 30 separate files to allow independent data analysis of each file. For instance, multiple Brinell files could be used and named HB1, HB2, etc. Each file will have its own tolerances, history, etc. The file name is user defined with up to 5 characters. The percentage of memory per file can also be set.

Press the 'STAT' key and then the 'NO' key until the display shows 'SPLIT MEMORY?'. Pressing the 'YES' key will cause the display to read "ENTER CODE". At this point enter the code for Split Memory. This will clear the history files to allow for reassignment of memory.

-The display will now read "HB1" If you wish to change the heading, press the Scale Select button to begin character selection sequence (see section on alpha/numeric characters in these appendices for details). If you wish to use the current heading, press ENTER to proceed.

-The display will read "HRC MEM PCT XX". The XX is the percentage assigned to this scale by default. The desired percentage can now be entered followed by pressing the ENTER key. The display will go to the next scale until all available scales have been displayed.

NOTE: Care must be taken when assigning percentages not to go over 100% or data will be lost. The History Function can be turned off so that test results are not stored in memory.

-Press the MODE key, then the NO key, until the display reads DISABLE HISTORY?

-Press the YES key.

-To turn Split Memory back on, repeat the procedure above. The display will read ENABLE HISTORY?, then press YES.

OPERATION WITHOUT SECURITY CODE ACCESS

The "CLEAR LAST" and "CLEAR ALL" functions will only appear if access is provided. "SEQUENCE NUMBER", "LOT NUMBER", and "STATISTICS" may be viewed but not changed without security code access. Split Memory appears but is controlled by a separate access code that must be entered to proceed with changes.

2.4.8 Print Functions

There are ten Print functions that may be used in conjunction with a printer:

- Totals
- Graph
- History
- X-Bar & R Chart
- Results/Values Only
- On Demand
- Print Off
- Trace
- Set Baud Rate
- Set Codes

These functions appear in sequence (with the possible exception of the Trace function and the Set Baud Rate) when the operator presses the NO key repeatedly. Samples of the printouts are included at the end of the section.

At Power Up the tester defaults automatically to Result mode which printout test values as performed. The Result mode slows down the tester operation slightly because the data is being transmitted to printer. To speed up operation without printer, remove Results function..

OPERATION WITH SECURITY CODE_ACCESS:

Note on Total and Graph Functions

These functions need tolerances to function properly. The operator may *add or change* tolerances at any time before they are cleared and reprint Totals and Graph. (See sample printout at the end of this section)

TOTALS (*see sample printout at the end of this section*)

Pressing YES causes the printer to print out the SPC values for the hardness results in memory. These values include number of tests, minimum, maximum, average, *standard deviation*, etc.

GRAPH (*see sample printout at the end of this section*)

If the YES button is pressed, the Graphics printout feature generates a frequency distribution diagram (histogram) showing the readings obtained in a certain lot grouped in ranges5 with the indication of number of results in each range.

These ranges are automatically scaled to the data and include spec limits, control limits and mean. Printing of the results does not affect the stored values, as these can only be cleared by specific command (or scale and calibration changes).

PRINT HISTORY (*see sample printout at the end of this section*)

If the YES button is pressed the printer prints the header with lot sequence #, zero set #, calibration status, lo and hi tolerance settings. Then the display asks:

HB1 HOW MANY?

The operator can select the number of tests he wants to be printed. if all the tests in memory are needed, enter 9999, followed by ENTER key. The format of the printout will display the sequence number, the hardness scale, the test result, and the tolerance result for high, low, or OK.

X-BAR & R CHART (OPTIONAL) *(see sample printout at the end of this section)*

The X-Bar & R Chart prints these two statistical charts (at right) for all the results stored in memory. The X-Bar (average) chart is always printed, while the R (range) chart is printed only if the average mode is in effect. If the results in memory are mixed single readings and averaged readings, the charts will show zero range for the single readings.

RESULTS/VALUES ONLY

These two functions toggle depending on which is selected. If “PRINT RESULTS?” appears on the display, selecting Yes will cause the Results print function to be activated. The next time the operator selects the PRINT Key the display will show VALUES ONLY.

When the RESULTS function is confirmed by pressing YES when “PRINT RESULTS” appears on the display, the results of each test will be printed after the tester performs the test along with values for lot number, sequence number, zero displacement, calibration status (with an asterisk), and tolerance settings. For a description of this data string see the Test Head Specifications section.

When the “VALUES ONLY” function is confirmed by pressing YES when the “VALUES ONLY” prompt appears on the display, the test value alone is printed without any tolerances or other descriptive information. This can be useful when the data is being exported to a computer.

ON DEMAND

This function allows the operator to print the results of the last test by pressing the YES button. The printout will appear in the History Data printout form.

If two tests are performed before the YES button is pressed the prior test will not be printed.

The On Demand function is deactivated by entering any other “Print” function, or answering NO to all Print modes.

PRINT OFF

Turns off printing from the PRINT Results or Values only Modes. Only appears in sequence if Results or Values Only Modes are turned on.

TRACE

If YES is entered at this point the Trace print function is activated, (if the PRINT key function has been enabled). This function will automatically cause results to be printed after each test. It will also cause every message which appears on the display to be printed. Whenever the Trace function is activated, the message which was on the display before

the PRINT key was pressed will also be printed out.

PLEASE NOTE: If the Trace function is activated, it will remain activated even if the security code procedure is later repeated without enabling the PRINT key again. If the PRINT key is not enabled, the Trace function will not appear as the operator views the Print function sequence so it cannot be deactivated. If this occurs, and the operator wants to stop the Trace function, the security code procedure must be performed again and the Print function enabled. Then, after pressing the PRINT key and returning to the Trace function, which will now be displayed, the operator must simply answer NO to the Trace function.

SET BAUD RATE

If the YES button is pressed, the display shows the current baud rate setting for the printer output. The operator may then select 300, 1000, or 9600 baud and press the ENTER key. If any other value is entered, "Incorrect Value" will be displayed. Note: "Set Baud" will not appear if the PRINT key has not been enabled. Refer to the printer manual for the correct setting for your printer

SET CODES

This function is generally reserved for factory use

OPERATION WITHOUT SECURITY CODE ACCESS

All the print functions can be performed without the security code access except TRACE, SET BAUD, and SET CLOCK functions.

X-Bar & R Printout

I-BAR CHART									
					59.5				
					Avg				
					59.2 : 59.7				
					UCL : UCL				
					V				
SEDI	DATE	TIME	HF60		60.0	61.0	62.0	63.0	64.0
1	1/10/90	12:33	59.4	:: + :					
2	1/10/90	12:34	59.4	:: + :					
3	1/10/90	12:34	59.5	:: + :					
4	1/10/90	12:35	59.4	:: + :					
5	1/10/90	12:36	59.5	:: + :					
6	1/10/90	12:36	59.5	:: + :					
7	1/10/90	12:36	59.6	:: + :					
8	1/10/90	12:37	59.6	:: + :					
9	1/10/90	12:37	59.7	:: + :					
10	1/10/90	12:38	59.7	:: + :					
11	1/10/90	12:38	59.6	:: + :					
12	1/10/90	12:39	59.7	:: + :					
13	1/10/90	12:39	59.6	:: + :					
14	1/10/90	12:40	59.7	:: + :					
15	1/10/90	12:40	59.7	:: + :					

RANGE CHART									
					.1				
					Avg				
					:				
					:				
					V				
RS04	DATE	TIME	RANGE		1.0	2.0	3.0	4.0	5.0
1	1/10/90	12:33	.1	:: + :					
2	1/10/90	12:34	.1	:: + :					
3	1/10/90	12:34	.2	:: + :					
4	1/10/90	12:35	.1	:: + :					
5	1/10/90	12:36	.1	:: + :					
6	1/10/90	12:36	.1	:: + :					
7	1/10/90	12:36	.0	:: + :					
8	1/10/90	12:37	.2	:: + :					
9	1/10/90	12:37	.2	:: + :					
10	1/10/90	12:38	.1	:: + :					
11	1/10/90	12:38	.0	:: + :					
12	1/10/90	12:39	.0	:: + :					
13	1/10/90	12:39	.1	:: + :					
14	1/10/90	12:40	.1	:: + :					
15	1/10/90	12:40	.2	:: + :					

Graph Printout

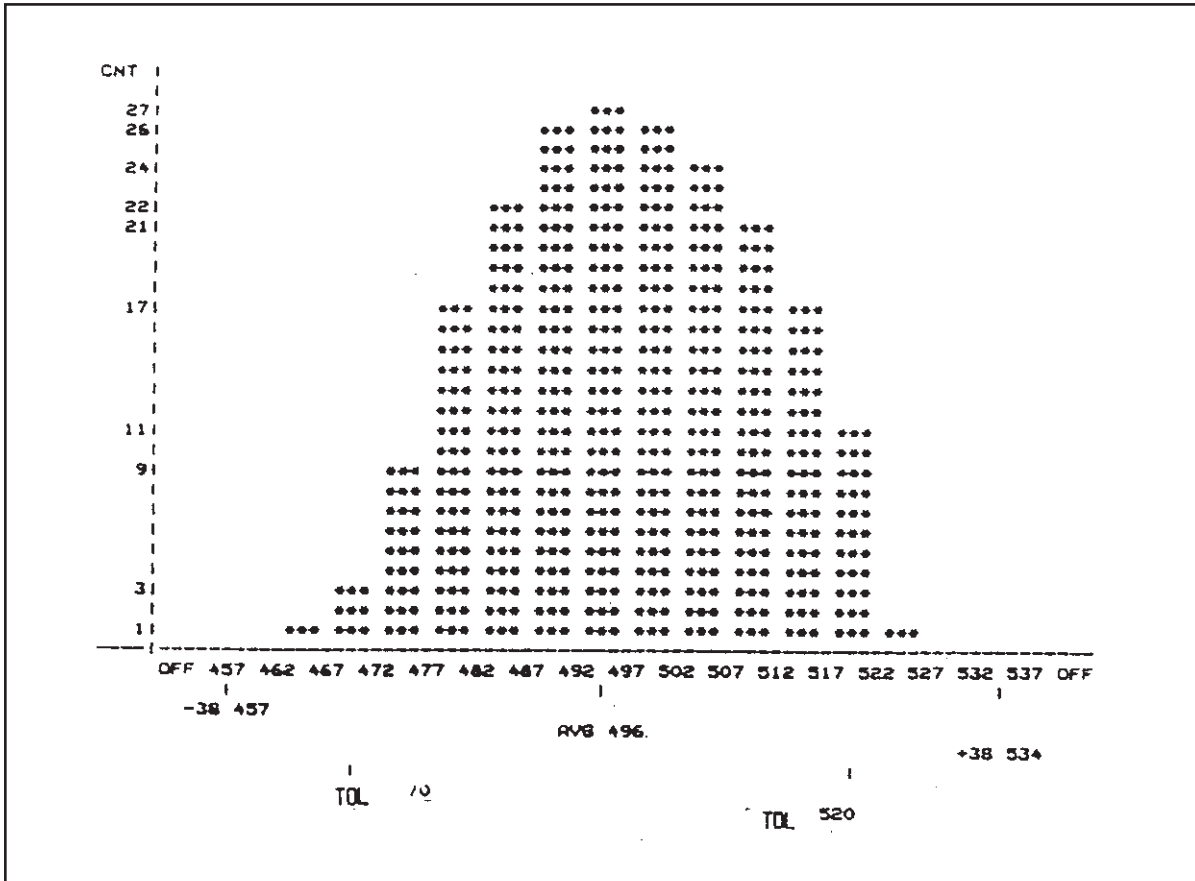

Totals Printout

LOT #	SEQ #	Z-DSP	CAL	LOWTOL	HIGHTOL			
102687930	64	100.0		63.0	64.0			
TOT	GOOD	LOW	HIGH	MIN	MAX	CPK	ZCALCMIN	ZCALCMAX
64	43-67%	3- 5%	18-28%	62.5	65.4	.09	1.136	.275
RANGE	AVG	VAR	STD DV	STD DEV	PRED % OUT LOW		PRED % OUT HIGH	
2.9	63.80	.501	(N-1) .707	(N) .702	(Z-TABLE MIN) 12.71		(Z-TABLE MAX) 39.19	
Z TABLE VALUES GREATER THAN .5%								

2.4.9 Mode Key Functions

There are 8 Mode functions : Time at Load, Diameter/Brinell Conversion, Minimum Thickness, Continuous-On, Average On, Diameter Results, Disable History, Set Clock . These functions appear in sequence as the NO key is pressed. All functions need to be enabled with security code.

TIMED LOAD

Pressing YES key enables the operator to view the currently selected time-at-load. Pressing ENTER key confirms that selection. Entering a new value followed by ENTER key changes the time-at-load. The timed load can be set from 0 to 99 seconds. 99 seconds will hold the test head down indefinitely.

DIAMETER/BRINELL

If the tester is displaying Brinell values, pressing the YES will cause the impression diameter for the last test result to be calculated from the Brinell number. An example of a diameter display would be:



HB-1 DIA = 3.05

This display shows the scale is HB-1 and a diameter in millimeters of 3.05. This message will be displayed until the NO key or another function key is pressed. If the tester is setup to display diameter measurements then the tester will display “Brinell?” and provide Brinell value conversions.

MINIMUM THICKNESS

Pressing YES will cause the minimum thickness value for the last test result to be displayed. This value is calculated as ten times the displacement value. an example of this display might look like;



HB-1 MIN = .1251N

This display would indicate the scale was HB1 and the minimum thickness was .125 inches. This display can give the minimum thickness value in millimeters (as indicated by an “MM” instead of “IN”). To switch back and forth from millimeters to inches press the YES key. This value will remain on the display until the NO key or another function key is pressed.

TRANSDUCER_CHECK

Pressing YES will cause the Continuous Display mode function to be activated. This function will cause the transducer input value to be displayed. For more information refer to the Transducer Section under Load and Penetration Depth Gauging.

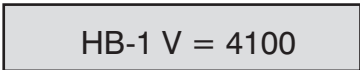

HB-1 V = 4100

HBI indicates the scale, 4100 is the LVDT input value.

AVERAGE

Pressing YES to the “AVG ?” query will select the Average mode function. This function will cause the printer to print out the results from a specified number of tests made on a specimen along with the range and average and also display the average on the readout. These average results will be stored under a single sequence number, and the individual test will not be stored. After selecting this function the first display will be:

HB-1 HOW MANY?

Enter any number from 2 to 10. Then the display changes to:

HB-1 READY

The operator performs the first series of tests. If the average of three tests was selected then the printout would occur after the three tests and would appear as follows:

1	200	204	205	RANGE = 5	
				AVG = 203	*H

At this time an indication of *H or *L if the average result is the highest or lowest so far in the sequence in a given series of averaged tests, the last *L or *H printed indicates the highest or lowest in the cited series. HI, LO, or OK tolerance indications also are printed if tolerances have been entered.

To turn off the AVERAGE function, press the MODE key, press the YES key to the AVG? query, and select “1” to the query for “HOW MANY”.

PLEASE NOTE: The average value is calculated to the first decimal. There is no round off from the 2nd decimal place value.

All TOTAL, GRAPH, and STAT functions use the average value in their calculations and printouts. None of the individual results are stored so only the averages are printed. (Optional programming is available to store individual results.)

If the operator uses the CLEAR LAST function during or after the sequence of three tests, the last test result (not the last average) is deleted. If the last test in a series is to be deleted the printer will repeat the printout using the same sequence number.

DIAMETER RESULTS

Selecting this function toggle between DIAMETER and BRINELL to cause all results to appear and be displayed and printed as diameter measurements or Brinell values

DISABLE HISTORY

Pressing the Yes key when the display shows “DISABLE HISTORY” or “ENABLE HISTORY” will cause the function to switch from saving test results in memory to not saving any test results or vice-versa.

When the history is disabled the test results are not stored in memory. Print and Stat functions will show only header information or “0” values (after a CLEAR ALL function from the STAT key). Disable History will prevent the occurrence of a “MEMORY FULL” message.

Press the NO Button to keep the settings the same and return to the READY mode.

SET CLOCK FUNCTION (OPTIONAL)

When this selection appears, press the “YES” key to display the date and time. The blinking digit can be changed at this point. Press the ENTER key to proceed to next digit until all digits have been entered.

Note: The date appears in 24 hour mode, i.e., 5:00 PM = 17:00

OPERATION WITHOUT SECURITY CODE ACCESS

No functions are accessible without the security code access.

2.5 Digital Readout Codes

These codes may appear on the screen. Here is a summary of their meaning:

NORMAL OPERATION DISPLAY CODES

*	Appears when the hardness scale in operation has been changed through an electronic calculation or zero displacement function.
“HI” “LO11 ‘OOK”	Indicates whether a hardness result fell within tolerance limits. Appears when the tolerance function is activated.
SELF TEST	Appears whenever the system is turned on or whenever the clear key is pressed while the system is in the test ready mode.
≡	Stands for the number sign, “#”.
MEMORY FULL	Indicates that the maximum capacity of this tester memory has been reached. The operator must perform a Clear All function to restore fresh memory. He may want to run a printout of results, a histogram or totals before clearing memory.
\bar{V}	Appears at right on the display. Indicates the factory set displacement Calibration has been changed. If this display appears the operator should call the factory.

OPERATION ERROR CODES

Whenever an error occurs during calculations or function selection, the error will be displayed and all the functions will halt until the error is cleared by pressing the NO key which will return the system to the test mode. These codes are:

CLEAR MEMORY	Appears when the display first comes on, instead of the display “SELF TEST”. This code indicates there is an error in the memory which must be cleared by pressing the YES key before testing can proceed. PLEASE NOTE: If this display appears, it indicates that there was an error in the system and all the results, statistics, and test parameters have been cleared out of the memory.
E5-E8	Indicates either system or operator error produced a bad test result.
INVALID TEST	Press NO to reset.
E9 MOTOR TIME OUT	If the operator presses the START (0) key while using a non-automatic tester, this code appears. Use the NO key to return to Ready status.

2.5.1 Routine Inspection and Emergency Return Checklist

Routine inspections are very important to perform on a daily basis, or if the machine is used less frequently, whenever it is turned on.

Emergency Return Checklist Items are to be performed whenever the test head retracts from using the Emergency Return Switch after the load has begun to be applied or when the test head retracts for an unknown reason.

Routine Inspection and Emergency Return Checklist

- Check test head centering/vee anvil alignment and check adjusting bolts for tightness.
- Check for tightness on all screws in the head and frame.
- Check safety device with cardboard test.
- Check calibration on test block.
- Check indenter shroud and indenter for deformation.
- Check anvil and fixtures for tightness and deformation.

Additional Emergency Return Checklist Items

- Check washer in the indenter shroud and replace if deformed
- Check load cell for proper positioning and tightness

Additional Maintenance Checklist Items

- Check hydraulic for clean filter
- Check hydraulic for proper pressure during test load
- Check hydraulic for proper pressure during UP cycle of test head
- Check hydraulic cylinder for dirt and scratches
- Check hydraulic cylinder for leaking

3. SPECIFICATIONS AND SERVICING PROCEDURES

3.1 Environmental

Temperature	0-50 degrees C (32-122 degrees F) (options available to extend temperature limits)
Humidity	0-95% Humidity

The system is designed for operation in industrial environments. However, being a sensitive measuring device, care should be taken to keep it fairly clean. specifically avoid dirt buildup on the head. The hydraulics footprint is 10" on a side (17" with projecting components)

* Dimensions listed are for unit without printer and hydraulics.

3.2 MECHANICAL CONFIGURATION

3.2.1 DIMENSIONAL SPECS

Dimensions:	Bench	Tester*	Complete*
Height	29-1/2"	49" (44-74" optional)	78-1.2"
Width	27-1/2"	19" (footprint)	27-1/2"
Depth	29-1/2"	25"	29-1/2"
Working Height	48" approx.		
Stroke	4" (optional strokes available)		
Capacity	8" vertical (16" without elevating screw), 8" reach (depth)		

The hydraulics footprint is 10" on a side (17" with projecting components)

* Dimensions listed are for unit without printer and hydraulics.

3.2 Electronic Output Specifications

- Serial RS-232 output
- The following is the format of the "Print Results" output of test values to the Printer.

String Output = SSSSS,PPPPPPNNNPAAAAA[CR][LF]

S = Sequence Number; P = Space; N = Result; A = Scale

Typical output = 1 94 HB1

Data is sent at the end of each test

The total length is 22 characters. All 22 characters are printed regardless of whether or not tolerance values are set. If tolerance values are not specified, the last 3 characters are blanks.

- The format of the individual bytes is as follows:
 - 1 start bit, 1 stop bit, 8 data bits
 - No parity
 - 300 Baud (The baud is adjustable - see Print Functions)
- Carriage Ret. and Line Feed Messages are sent after the 22 character string.
- Connector: Amphenol Type 703-91T3300-1
- Pin Assignment:

1 Serial out	3 Busy
2 Ground	4 N.C.

3.3 General Description

The test head contains the load and dimensional gauging sensors and a number of switches to control the test parameters. It is connected by bolts to the hydraulic cylinder.

Several electronic cables are also attached to the sensors on the test head. A yellow shield covers these sensors and provides access for service. The sensors run to the electronic readout box and the top of the stand frame.

The sensors consist of a preload switch on the back of the test head, the LVD transducer to measure the depth of indentation, the safety device, and the load cell to control the test load. A sensor on the stand column is the Home/Overtravel sensor. At the top of the stand is an Emergency return button which can automatically cause the hydraulics to retract.

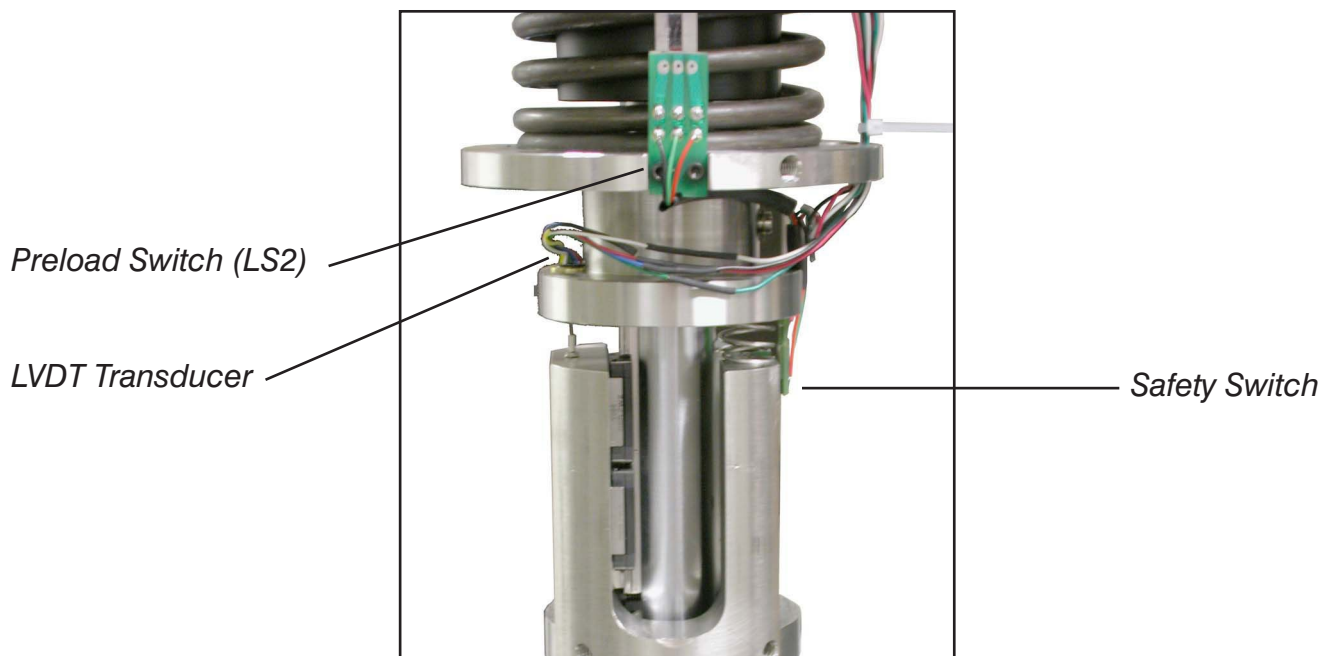

**Test Head Electronic Components
(shown with cover removed)**

3.4 Tester Components

Tester Components

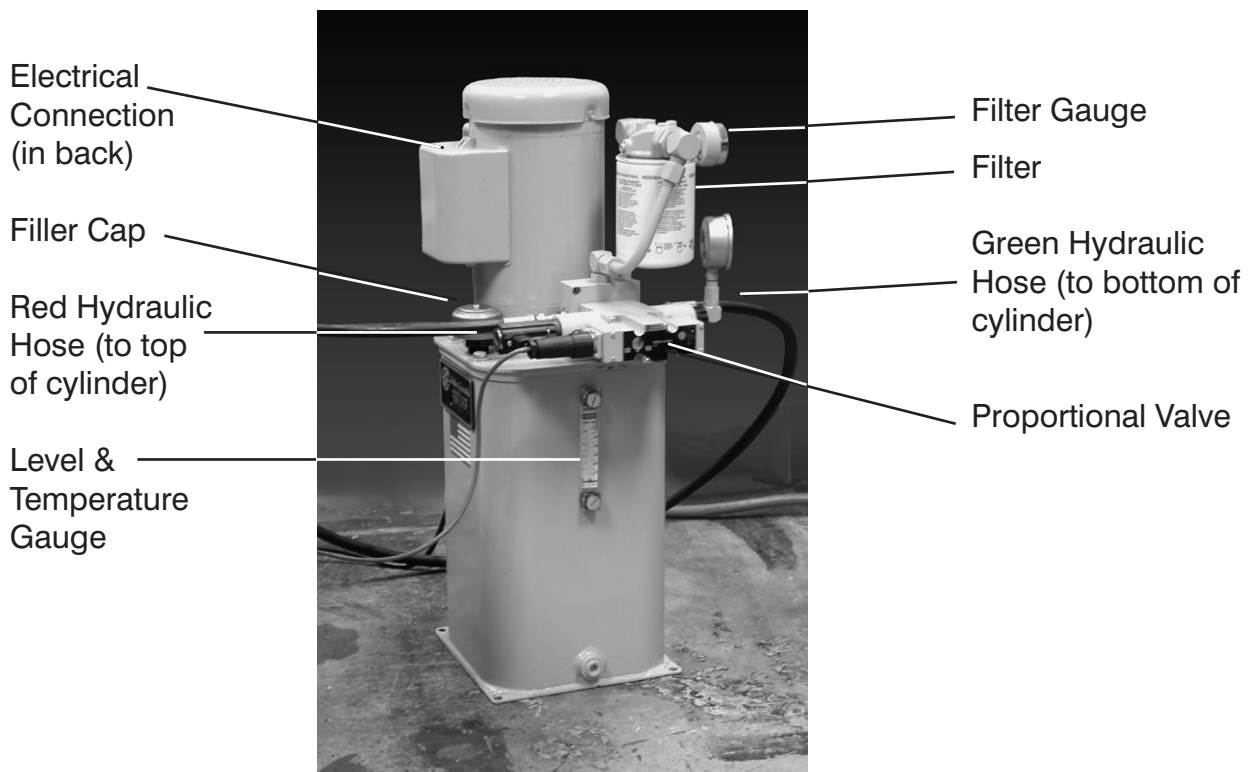
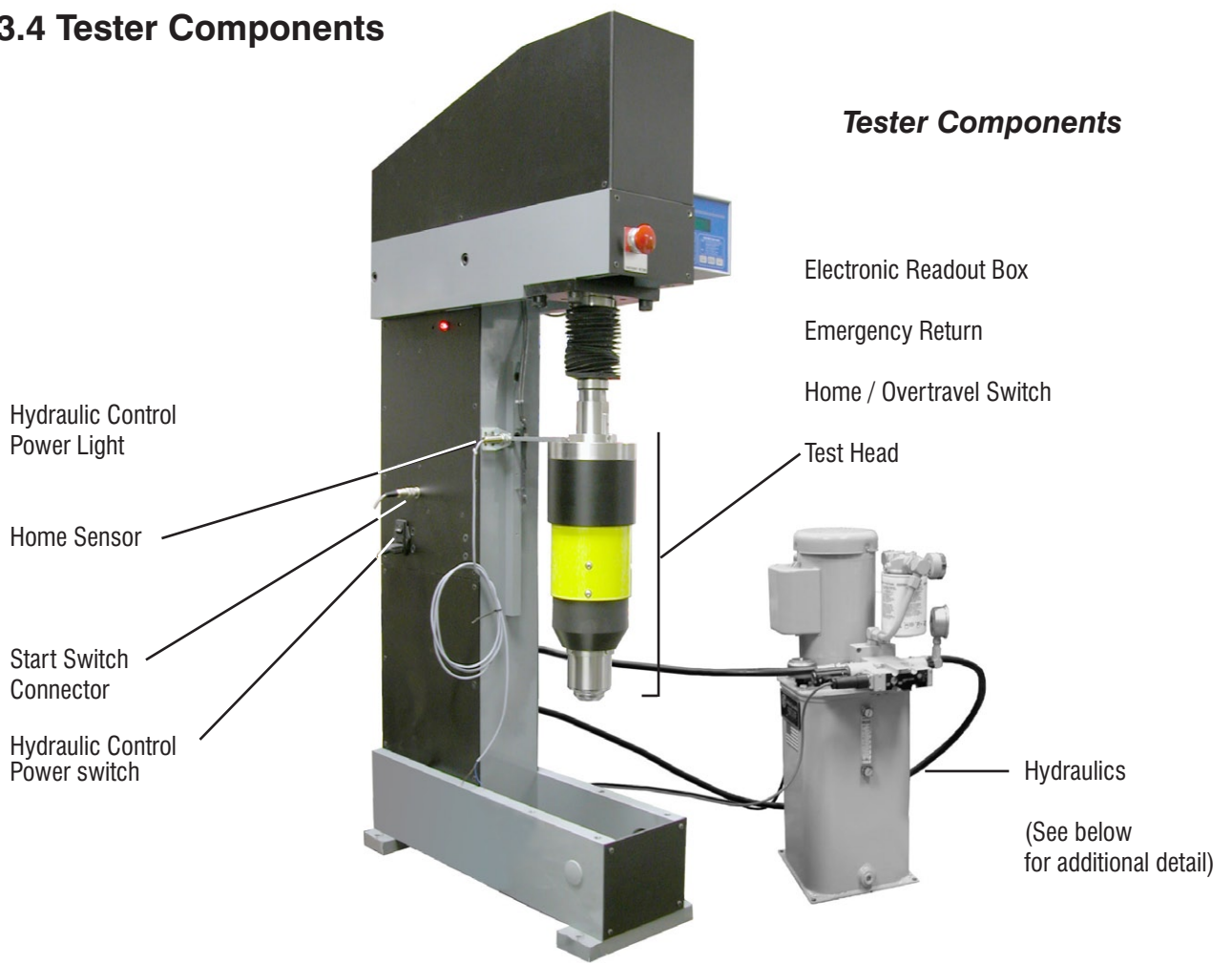

3.5 Routine Procedures

3.5.1 Indenters and Shroud Removal/Install

The indenters and indenters shroud may be removed using an allen wrench and [2] open box wrenches. The shroud is mounted with three allen screws. Tighten screws evenly; there is a gap between the bottom of the head and the Chromed Shroud ring (See below).

WARNING: When changing the indenter, hold the indenter holder with a second wrench in order to avoid damage to the internal head bearings. Refer to picture below.

The indenter consists of a tungsten carbide ball welded to a threaded shaft. The standard shroud uses a spring-loaded nose piece to tilt for testing on tapered specimens. After removing the shroud, the indenters may be removed by unscrewing it with the 13mm wrench in the accessory kit.

Note: There is a gap between the ring that holds the shroud in place and the square plate where the screws thread into.

Note: Make certain the indenters is firmly threaded in place.

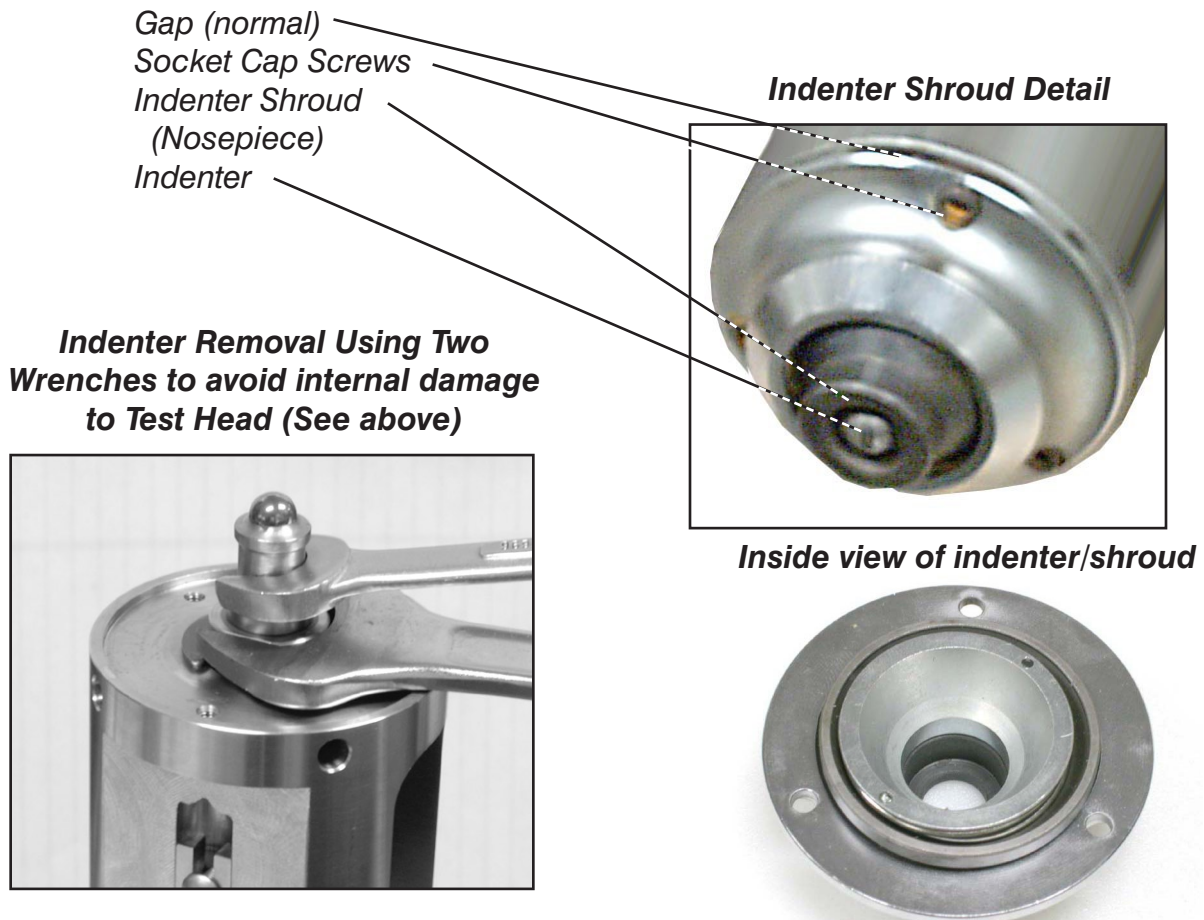

3.5.2 Test Head Removal and Mounting

The test head can easily be removed by unscrewing the 3 set screws that are counterbored into the plate located at the end of the cylinder. Before removing the head, the electrical connections at the back of the head should be undone, and the power turned off.

*3 set screws
(around
circumference)*



3.6 Hydraulic system

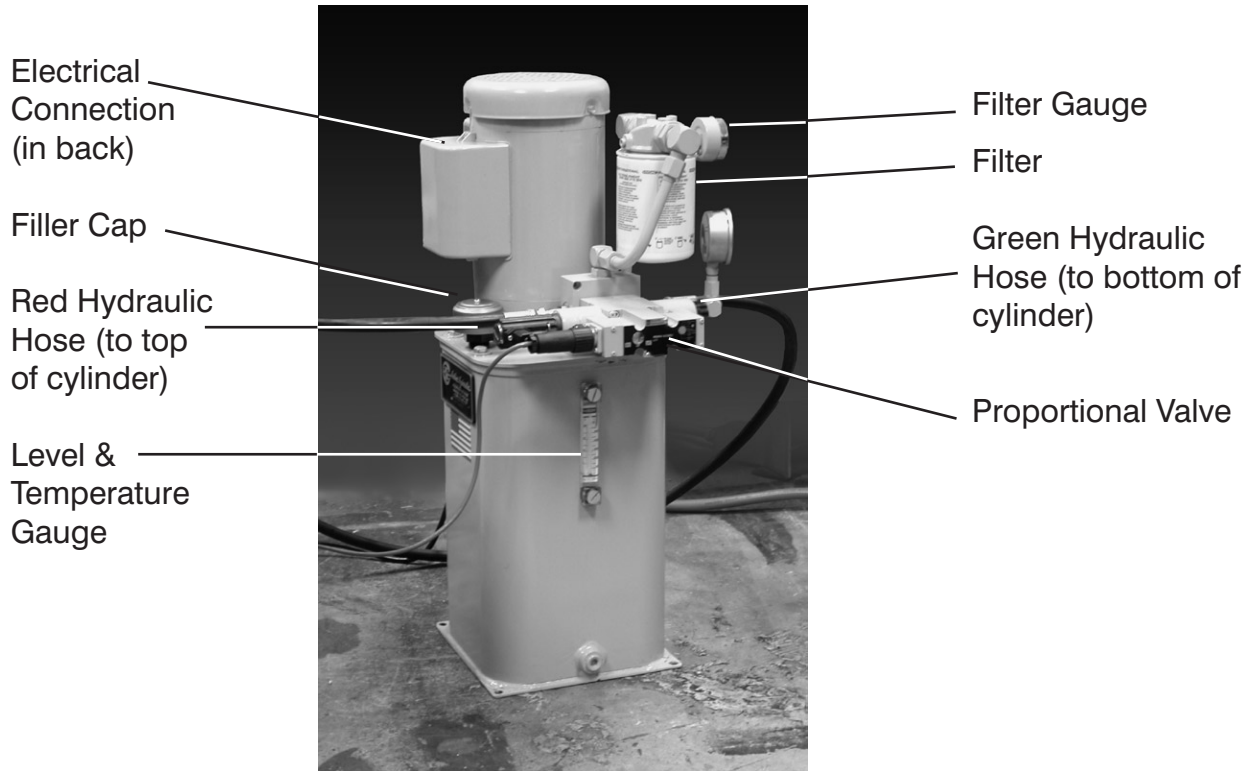

<p>ZERO ADJUSTMENT</p> <p>Drive cylinder midway down the stroke and adjust zero potentiometer until the cylinder moves slowly upwards. This will keep the cylinder at the home position when not in use.</p>	<p>RAMP ADJUSTMENT</p> <p>Turn counterclockwise all the way.</p>

Proportional Valve adjustments

3.7 Load and Penetration Depth Gauging

3.7.1 Load Cell

The load is controlled through a load cell. Depending on the load various models may be used.

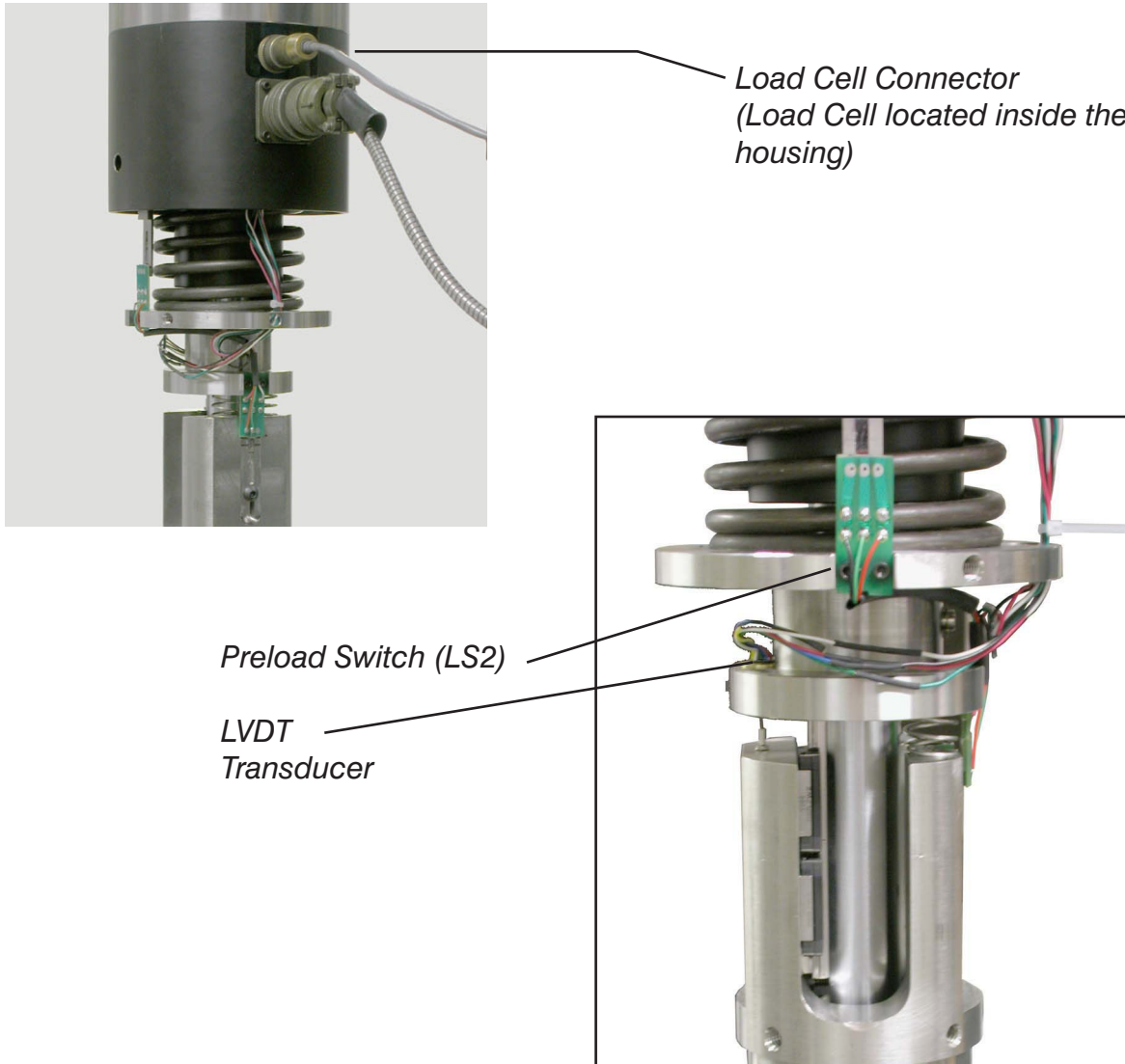

3.7.2 Safety Device Checking and Adjustment

This feature detects materials that are too soft to be tested (below HB 50), and will retract the head if the operator should get his hand under the indenter shroud. (CAUTION: This safety device will help reduce the degree of injury to an operator, but severe injury may still result.) Fixture the part properly so that operator does not have to keep his hands in the indenter area.

To check its function, put a double piece of cardboard on the anvil and make a test. The indenter should make a small dent in the cardboard and immediately retract without punching a hole through both layers. The tester can also be checked using a test specimen that has a hardness of under HB 50. If adjustment is needed, loosen the screw. To make the safety switch more sensitive, move the magnet that activates the switch upwards, and vice versa.

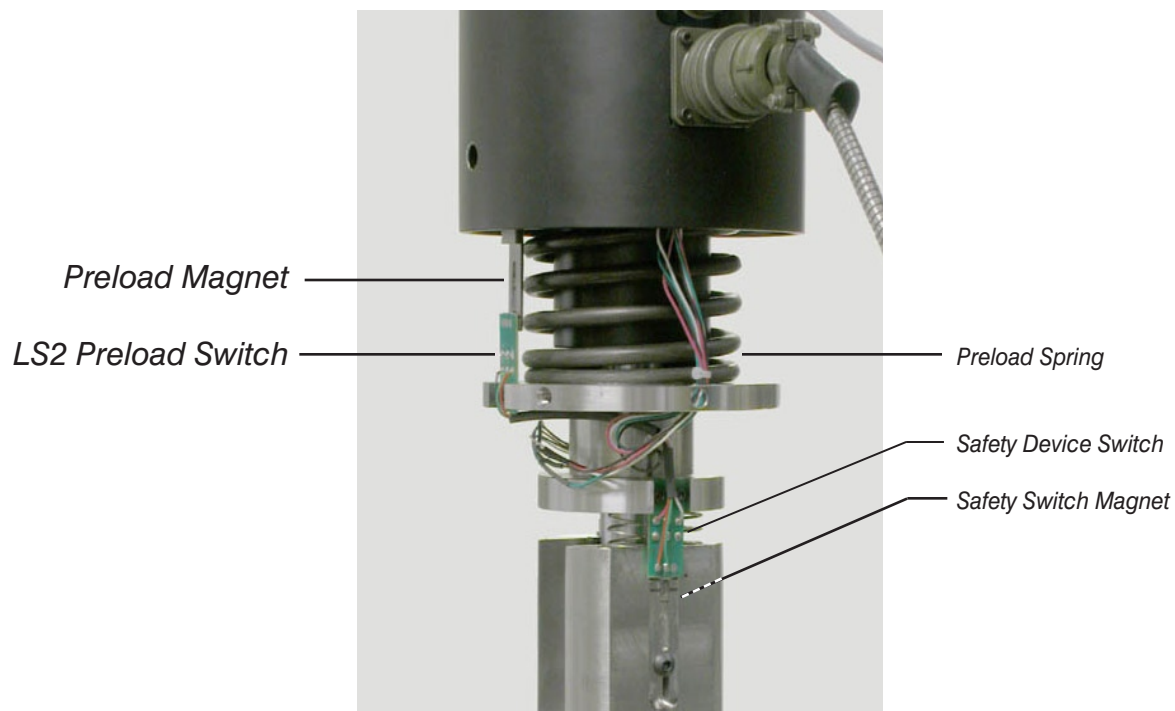

3.7.3 LS2 - Preload Switch

(Contact factory before making adjustment.) This switch controls the preload signal to the electronics to zero the preload reading and initiates the reading of the depth of penetration at the full load position. Its output is normally high (+5V DC), it goes to 0 when activated.

The proper position for this switch is indicated by a number of checks. 1) Jog the test head down to the anvil, stopping just before contacting the test piece and continue traveling downward until the indenter contacts the test piece. At this point the preload spring starts to compress, and the preload switch moves relative to the preload switch magnet by about 1/4". Watch the display of the readout unit for test cycle being entered (the display changes from previous result to active display mode). This transition should occur at 1/8" midway through the 1/4" total travel. Adjust preload magnet holder if necessary.

3.7.4 Transducer

(See Photo/drawing for Load and Penetration Depth Gaging)

Transducer: LVDT with +/- 1mm accurate travel and 0.001 mm resolution

The transducer is located in the test head under the yellow cover per the illustration (preceding pages). It is verified for proper positioning by checking its output. To check the output, press the MODE key on the keypad, and move to the Transducer Check function. (Refer to the Keypad Operation section of the manual.) When the Transducer Check function is activated the display will show the transducer output. This number tracks the position of the indenter relative to the shroud (or vice-versa). Moving the indenter shroud up and down should make the number change from below 1000 to above 7000. If this does not happen the transducer may be in the incorrect position. To reset it, loosen the screw that clamps the transducer into position and manually slide the transducer up or down. As the transducer moves the display will change. When the correct setting is reached at 4000 +/- 100, tighten the transducer screw. **DO NOT OVER-TIGHTEN**. For transducer calibration, move the nosepiece relative to the indenter exactly 0.500 mm (use gage blocks or a micrometer screw) and the display number should change by 1515 counts +/-15. If adjustment is needed, turn the potentiometer "Z" on the analog board (see Electronic Box Diagram Section, Analog Board drawing).

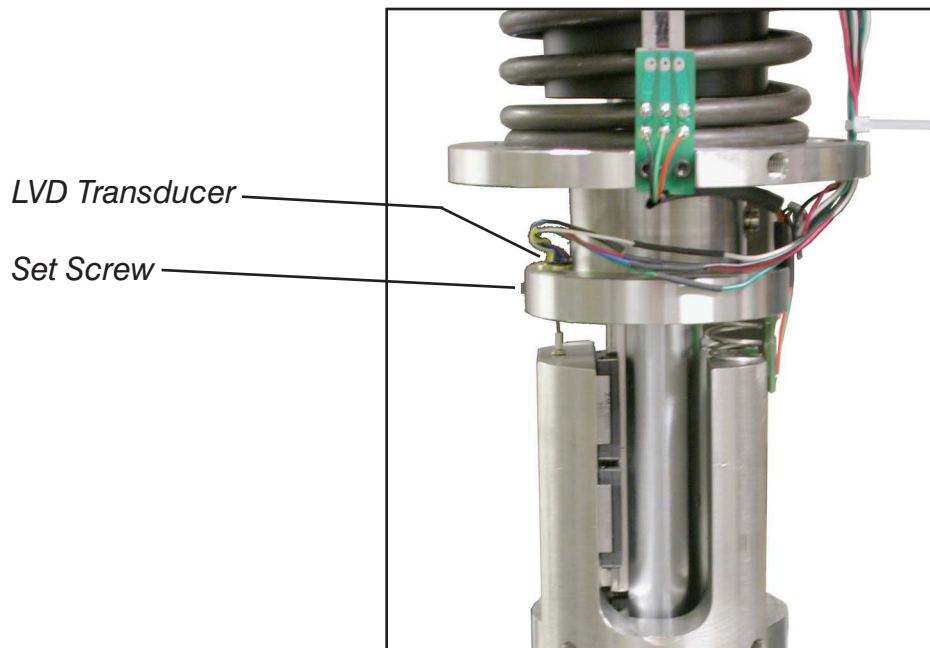

3.7.5 Load Calibration

The load calibration is the primary verification since it is a basic constant in the Brinell test. The load can be verified using a proving ring or a test block. When using the proving ring, place a test block on top of the ring. This prevents the ring from activating the emergency device. The standard load is 500 kg, Make certain the proving ring is properly placed on the anvil in a stable loading position. With the machine running properly, the load on the proving ring should be within +/- 1% when the tester is at full load.

Note: The nosepiece adds 6.7 kg to the total test force. Either lift the nosepiece or consider it as part of the load and calibrate the machine at 506.7 kg.

A test block may also be used for indirect verification of load. When using the test block to calibrate the load, take several tests and read the results optically. (Do not use the results on the display.) The difference between the minimum and maximum result should not be more than the range of the test block. If there is a consistency problem, it should be corrected before calibration is attempted (see Troubleshooting guide). If the results are consistent, take the average value and compare it with the value on the block. It should be within +/- 1%. If load adjustment is necessary, please use a proving ring to check the load before making adjustments.

PLEASE NOTE: Keep in mind that when using a test block to calibrate the load that other factors may offset the reading such as inaccuracy of the block itself or inaccurate optical readings by operators. The best verification of the load is with a proving ring.

3.7.6 Electronic Adjustments

To access remove right-side (facing the tester) panel between the upright columns.

Up Speed Adjustment

Adjust for smooth movement upwards after loading time.

Down Speed Adjustment

Adjust for maximum speed possible without force overshoot.

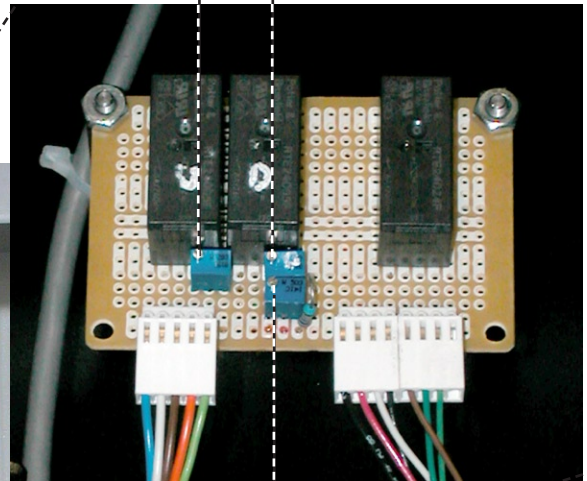
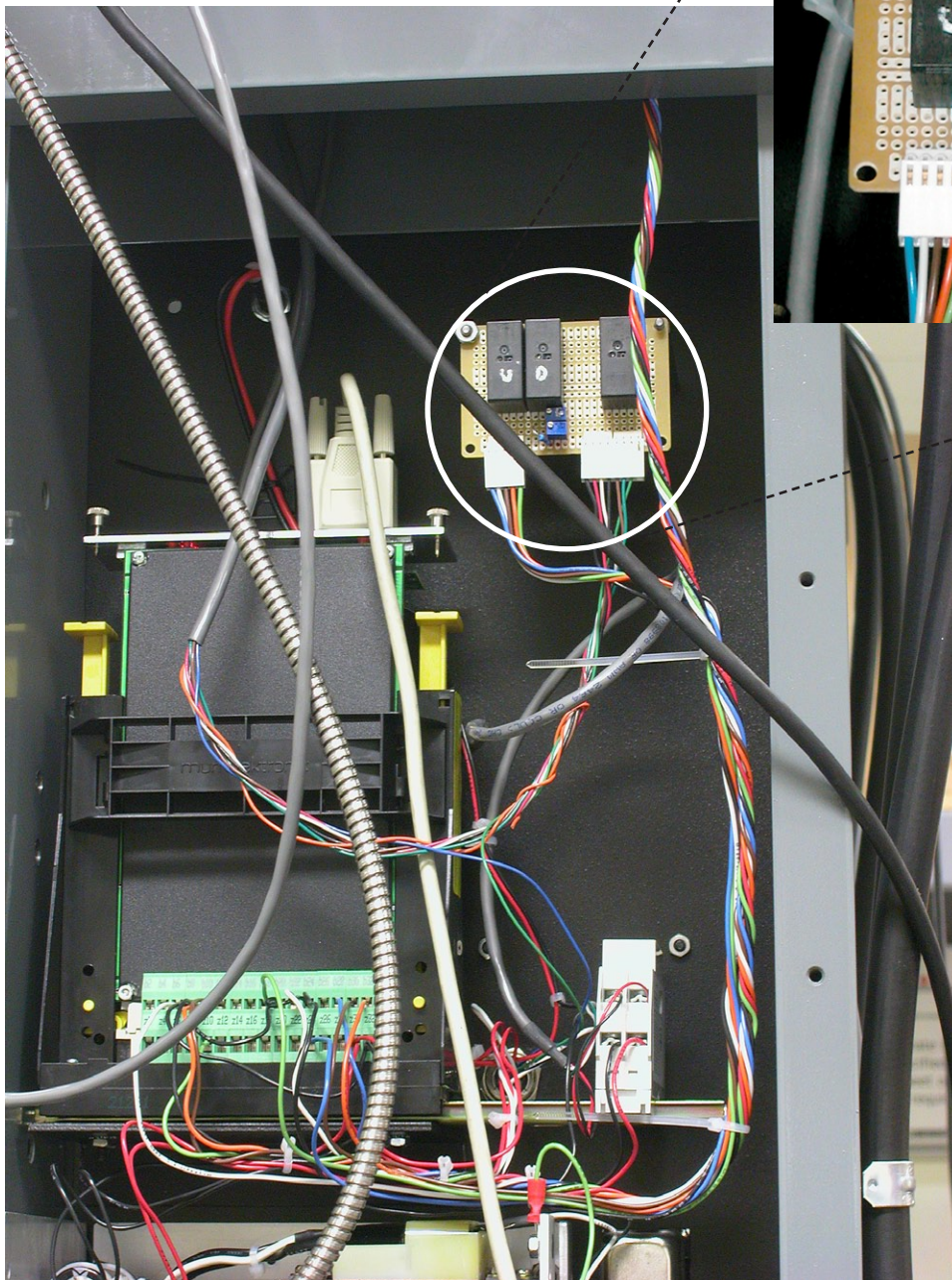

Force Adjustment

Adjust if load cell or proving ring shows incorrect force applied.

3.8 Electric & Electronic, Power Requirements & Outputs

3.8.1 Power Requirements for the Electronic Control Console

One outlet 120V 50/60HZ isolated power line.

3.8.2 Power Requirements for the Hydraulic Unit

110/230V (single phase) or 230/460V (3-phase). Verify on motor plate.
Check motor rotation.

3.8.3 Electronic Output

- Serial RS-232

String Output = SSSSS,PPPPPNNNPAAAAA[CR][LF]

S = Sequence Number

P = Space

N = Result

A = Scale

Typical output = 1 94 HB1

Data is sent at the end of each test

The total length is 22 characters. All 22 characters are printed regardless whether or not tolerance values are set. If tolerance values are not specified, the last 3 characters are blanks.

The format Of the individual bytes is as follows:

1 start bit

1 stop bit

8 data bits

No parity

-The baud rate is 300, b bit, no parity.

- Carriage Return and Line Feed messages are sent after the 22 character string.

- Connector; Amphenol Type 703-UIT3300-1

- Pin Assignment: 1 Serial out
 2 Ground
 4 N.C.

3.8.4 Electronic Box Diagram

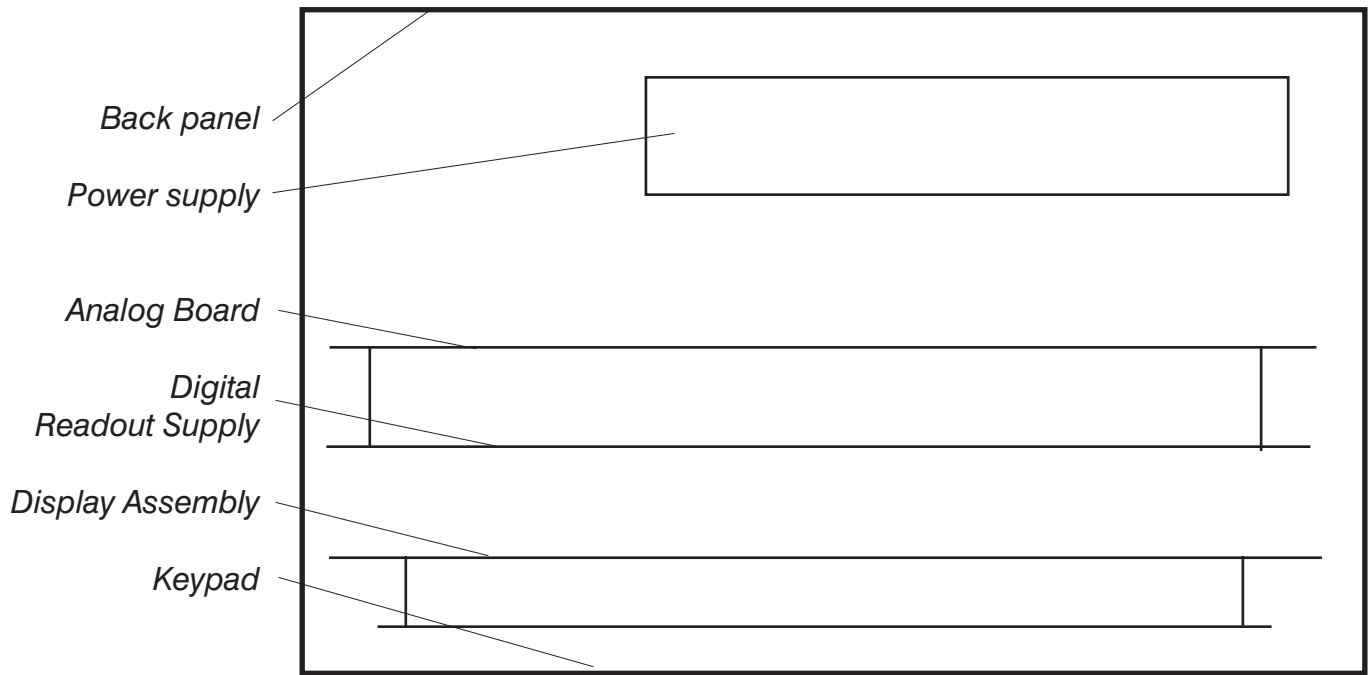

Top view of electronic box

Analog Board (AB)

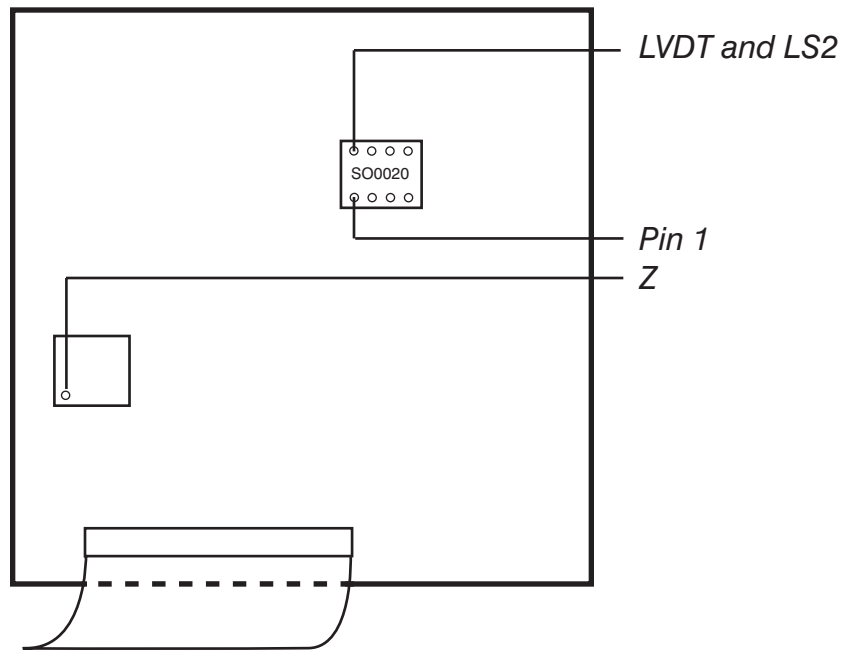

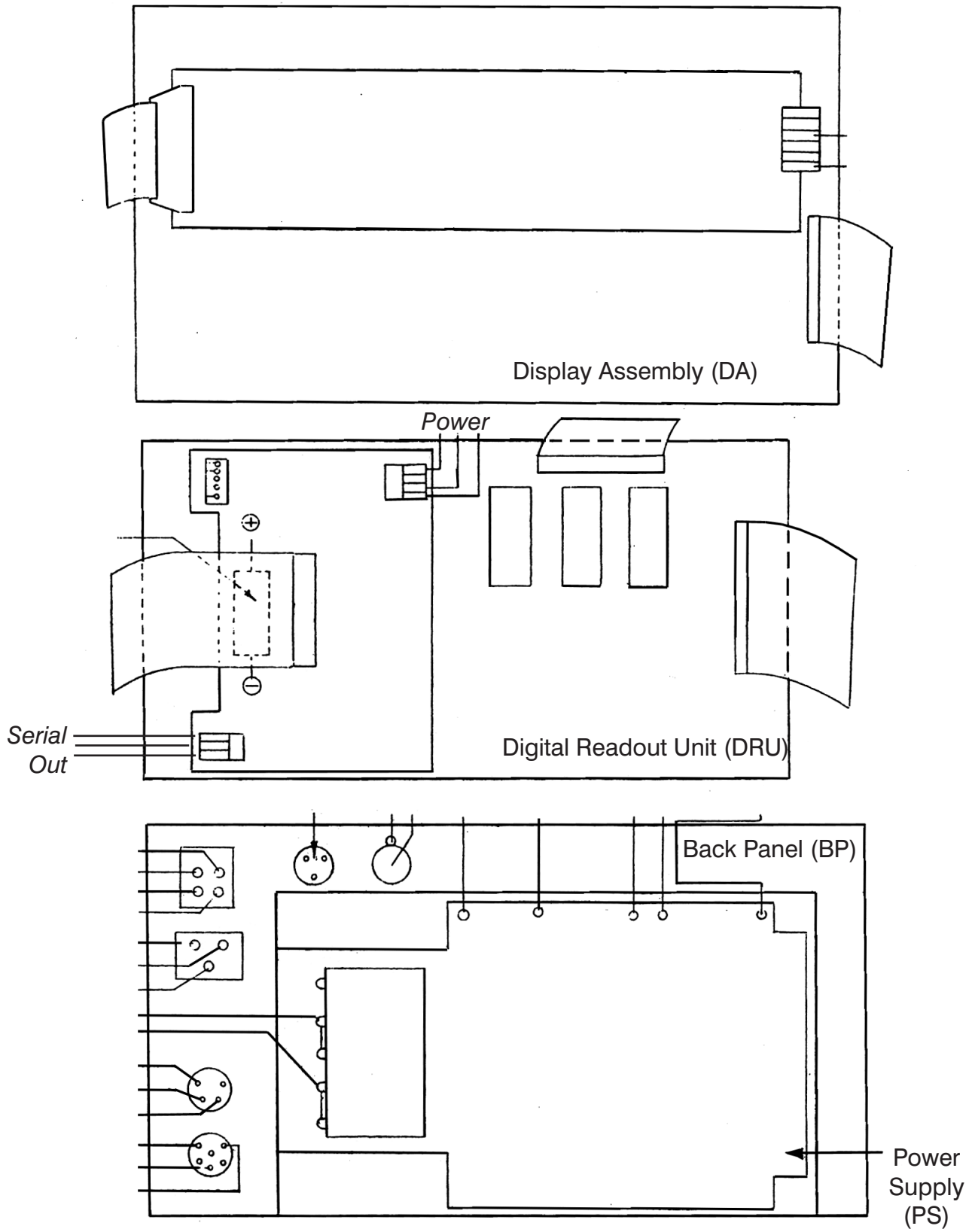

3.8.5 Electric Cables and Pin Assignments

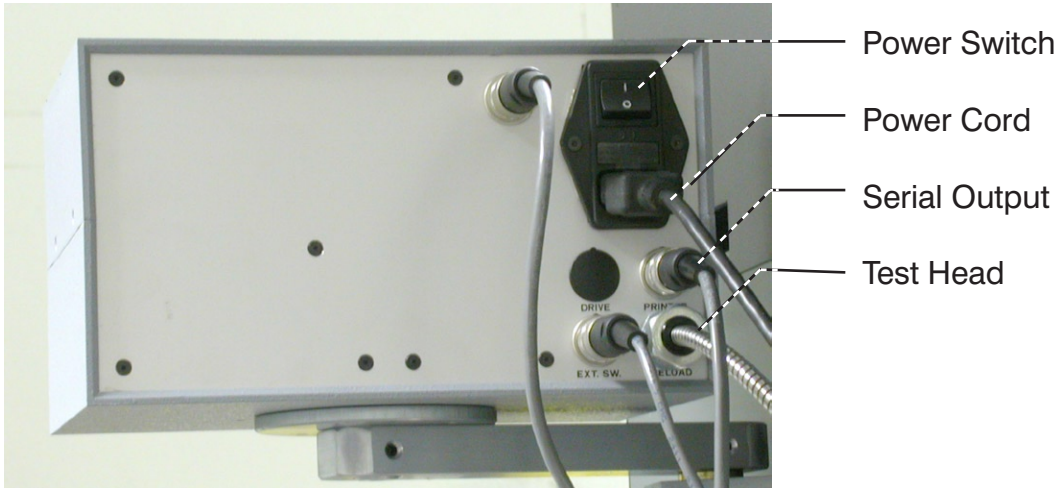

Rear View of Control Unit

**Amphenol 3106A
22-14P to test head**

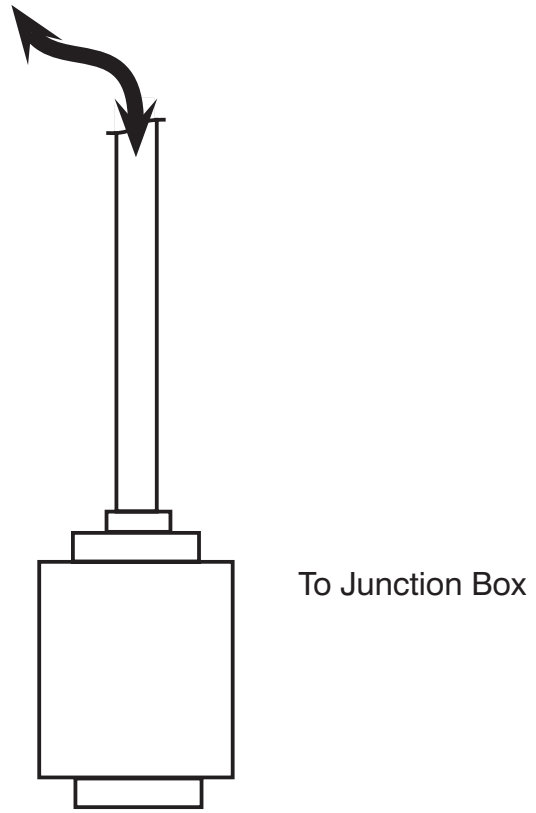

Pin Assignments

A - Orange	Spare
B - Gray	Spare
C - Black	Gnd Power Supply
D - Red	Pin 6 of SO0020
E - Blue	Pin 5 of SO0020
F - Green	Pin 8 of SO0020
G - White	Pin 4 of SO0020
H - Brown	Pin 1 of SO0020
K - Yellow	Emergency
J - Purple	+5V Power Supply

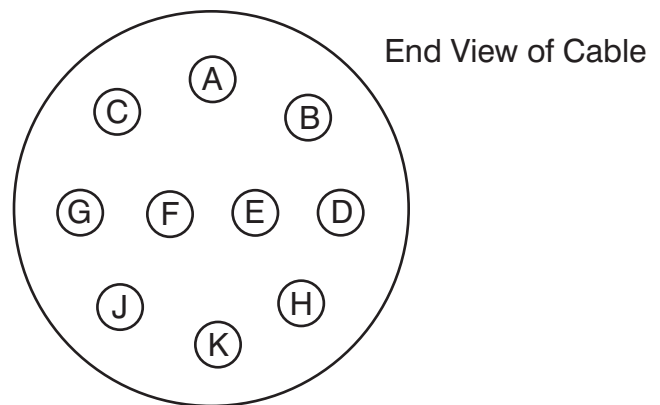

4. TROUBLESHOOTING

PROBLEMS	CAUSE	SOLUTION
The cycle does not start	Hydraulic motor is not running	Check electrical and hydraulic system
	Pressure relief hydraulic valve not working	Check solenoid valve and fuse in electronic console
	System not in test mode	Complete keypad function or clear it by pressing NO
	System needs reset	Turn reset key and Press reset button
Wildly erratic test results	Power line to the electronics is not clean	Install power isolation equipment
Test head retracts before load is applied	Test surface is lower than the maximum stroke	Raise the specimen close to the test head
	Test specimen is too tapered or otherwise causes safety device activate	Provide proper fixturing
Test Head retracts after load begins	Part shifting	Provide proper fixturing
	Part too soft	Test parts over HB 100
Test results won't print	Printer not turned on	Turn on printer
	Printer out of paper	Feed paper into printer
	Print function on electronics no activated	Follow print function routine
Unknown symbol on readout	Function error	Refer to Digital Readout Codes section

PROBLEMS	CAUSE	SOLUTION
Head does not retract after a test	Fuse blown	ReplaC2 fuse
Test results not accurate	Test Specimen not within two degrees of level	Fixture part (see Fixturing section)
	Depth/width calibration not set	Follow calibration procedure
	Load calibration not accurate	Follow load calibration procedure
	Test specimen is rocking during load	Fixture to eliminate rocking
	Transducer calibration not set properly	Calibrate transducer (using optional calibration fixture)
	Preload calibration not set properly,	Adjust preload
	Indenter or Nosepiece is damaged	Replace damaged part
	Loose indenter	Remove shroud and tighten indenter

5. SERVICE AND SHIPPING

FOR SERVICE INFORMATION, SHIPPING INSTRUCTIONS, AND TEST HEAD REPAIRS

CALL: 800-806-3924 or 215-526-2200; Fax: 215-526-2192

MAKE CERTAIN YOUR INSTRUMENT NEEDS TO BE SERVICED:

Test Stands: Often components can be installed at your plant by your maintenance personnel or Newage representative. Call Newage Customer Service Department if you need assistance.

Test Heads: If the test head will not operate correctly after following the troubleshooting procedures and/or calling Newage support personnel, see below for shipping instructions:

IF YOUR TESTER DOES NEED SERVICE:

1. The indenter and its shroud should be screwed into the head. Any additional indenters should also be included in shipment.
2. Write the name and phone number of a person who can authorize the repair expense. (Newage will call with an estimate after looking at the tester.) Also, include a brief description of the tester problem or requirement, e.g. *Needs calibration* or *Reads high*.
3. Place head, and related accessories in a sturdy box (double-wall cardboard or double boxed, leaving room for at least three (3) inches of fire packing material).
4. Pack the box so the head will not shift in shipment and be certain the test head and electronics will not be damaged by movement of the head. Mark package with labels indicating "Sensitive Instrument. Handle with care".
5. Ship via UPS and insure for the value of the test head.

6. Ship to:

Newage Testing Instruments, Inc.,
147 James Way,
Southampton, PA 18966 USA
800-806-3924 or 215-526-2200

NOTE: When packaging delicate instruments for shipment maximum care must be taken. Please instruct your shipping department to take as many precautions as they can: Double box the test head or use a double wall box and provide adequate padding and support so the tester is not damaged in shipment. The test head is very heavy.

NOTE: Newage policy for warranty repairs is for customer to pay shipping to Newage. Newage will pay charges for shipment back to customer

TO SCHEDULE CALIBRATION

Call Newage Testing Instruments in Indianapolis 800-317-1976 or 317-329-4300

6. ONE YEAR LIMITED WARRANTY

Should Newage Testing Instruments, Inc. equipment require service, we will repair or replace, at our option, any part or product which upon examination by a Newage service technician, shows to be defective in material or workmanship. Excluded from this warranty are any parts that are to be replaced as part of normal product operation, such as indenters, test blocks, and indenter shrouds.

This warranty is extended to the original purchaser only, for a period of one year (12 months) from owners date of purchase.

This warranty IS NOT VALID IF THE INSTRUMENT HAS BEEN MODIFIED, MISUSED OR DAMAGED in any way. This includes damage caused by disassembly by any person other than an authorized Newage Testing Instruments' service technician.

Please read all operating instructions according to the manual supplied with the instrument prior to operation. This warranty applies only to instruments sold by Newage Testing Instruments, Inc. and its authorized distributors.

Newage Testing Instruments, Inc. is not responsible in any way for losses, damage, or other form of consequential damage resulting from equipment failure or improper use.

IMPORTANT: Register your instrument with Newage Testing Instruments, Inc. service department by filling out and returning the enclosed warranty registration card



147 James Way, Southampton, PA 18966 USA
Tel: 800-806-3924 or 215-526-2200 Fax: 215-526-2192
Email: info@newageinstruments.com
Website: www.hardnesstesters.com