



Rockwell Hardness Testing System

Versitron®

The **Industry** Workhorse

- **Accurate** for the Lab, **Tough** for the Shop

35560 Grand River Ave, #420
Farmington Hills, MI 48335
P: 248-676-1007 / E: sales@z-checkcorp.com
Website: www.z-checkcorp.com

Tough & Reliable

Protected Diamonds

The removable clamping shield protects the recessed diamond indenter from being struck by the test specimen during handling. Furthermore the indenter is protected from damage resulting from test samples shifting under load.

Test Surface Referencing

Immediately surrounding the indenter is an indenter shroud. The purpose of the shroud is to sense the position of the indenter relative to the test surface when the preload has been applied. Should the test specimen deflect under major load, the shroud travels with the test surface to compensate by maintaining that precise reference position with the test surface, so the test result will remain accurate. The error resulting from deflection can be eliminated or substantially reduced as the test results are not sensitive to dirt. A hair under a test block will completely ruin most testers' results but the Versitron remains accurate. And situated in good environments it requires less cleaning and maintenance.

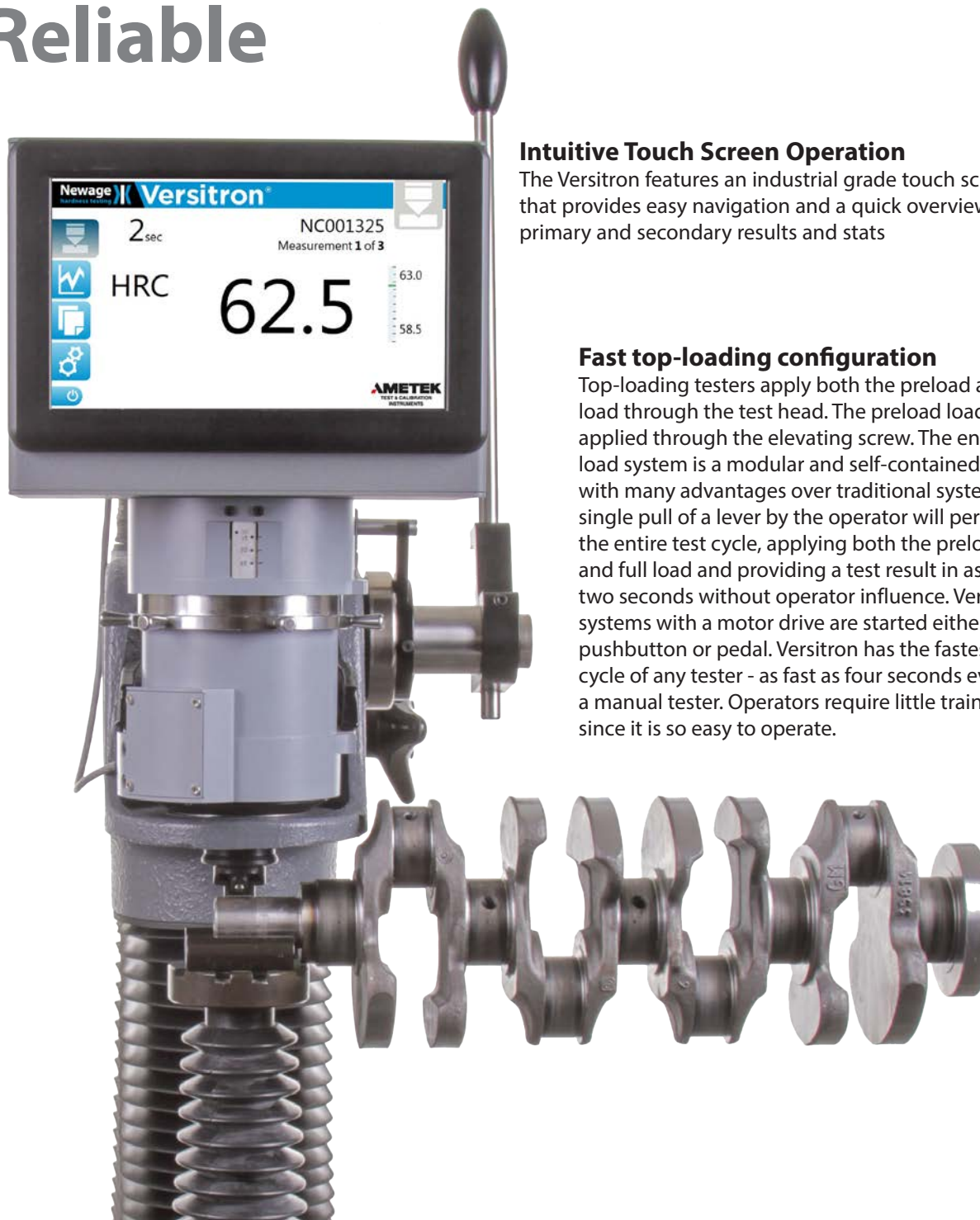

Intuitive Touch Screen Operation

The Versitron features an industrial grade touch screen that provides easy navigation and a quick overview of primary and secondary results and stats

Fast top-loading configuration

Top-loading testers apply both the preload and full load through the test head. The preload load is not applied through the elevating screw. The entire load system is a modular and self-contained unit with many advantages over traditional systems. A single pull of a lever by the operator will perform the entire test cycle, applying both the preload and full load and providing a test result in as few as two seconds without operator influence. Versitron systems with a motor drive are started either with a pushbutton or pedal. Versitron has the fastest test cycle of any tester - as fast as four seconds even on a manual tester. Operators require little training since it is so easy to operate.



Heavy-Duty Clamping

The ability to clamp test parts in the test cycle reduces the time spent on using jack screws or cutting specimens. Clamping is accomplished independent of any applied test loads. The capacity is about 240 foot-pounds (325 Nm) so operators can clamp nearly anything they can lift. Even tapered parts can be clamped using ball anvils. The clamping shield pops in and out without tools so operators can perform small sample testing easily without the clamp.

Intuitive Operation

The rugged industrial grade touch screen provides easy navigation and a comprehensive overview of measurements, settings or statistics. The left hand pane enables quick navigation between the four main screens: test, statistics, file management and test setting.

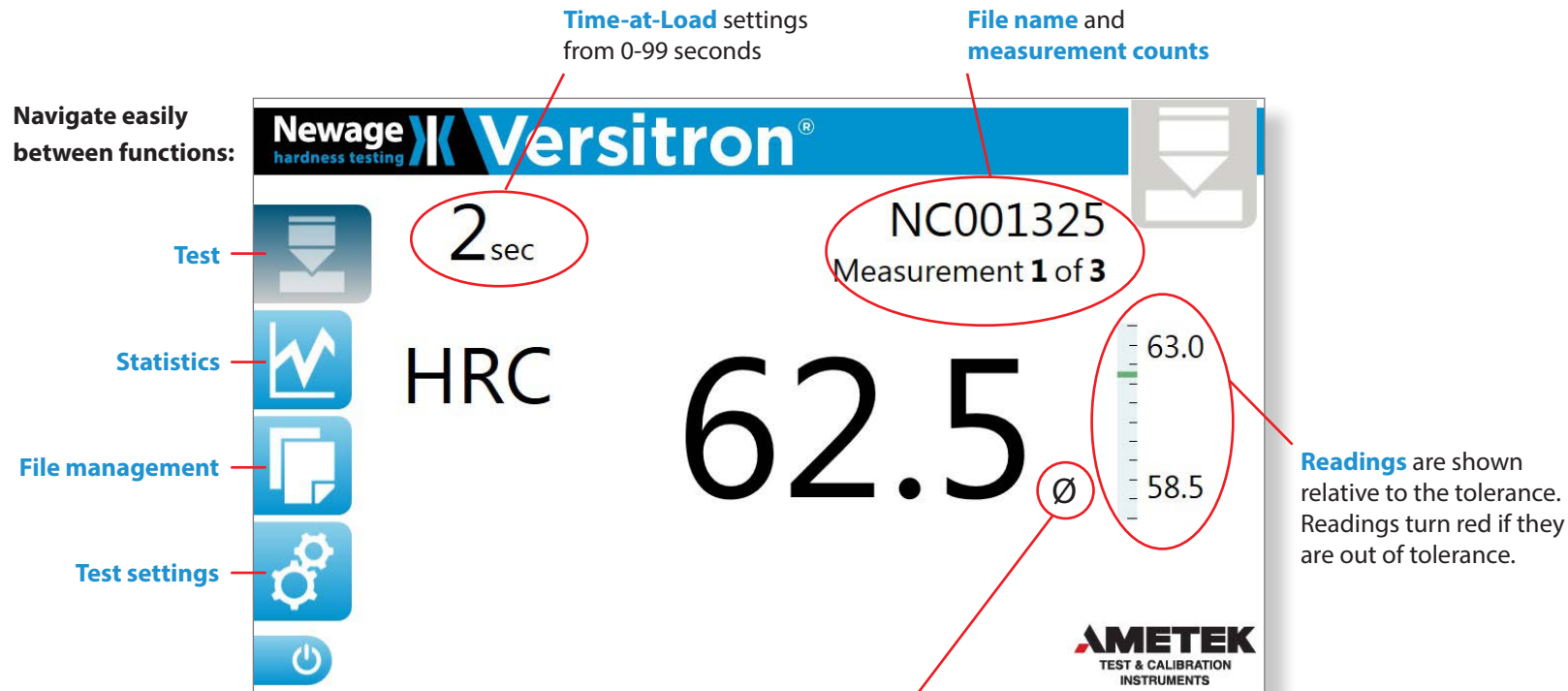

Automatic Hardness Conversion
Automatically convert a test result to another hardness scale, per ASTM E140.

Roundness correction
Shown next to the reading if selected.

Readings are shown relative to the tolerance. Readings turn red if they are out of tolerance.

The Versitron has the capacity to amaze first time users. Most experienced testing personnel are quite familiar with tedious requirements like using jack rests on large parts, constantly cleaning testers and test parts, slow test cycles and cutting parts so they can be tested. The Versitron changes all of that. Large and small companies all over the world now find they can get fast, accurate, and repeatable test results even in bad operating conditions using relatively unskilled operators without significant service requirements.

Easy Setup

Newage | Versitron®
hardness testing

NC001325 Dataset: NC001325

3) 62.2	3 of 3 (HRC)
2) 62.6	Average: 62.4 Pass: 3
1) 62.5	Std Dev: 0.21 Fail: 0
	Max: 62.6
	Min: 62.2
	High Tol: 63.0
	Low Tol: 58.5

Delete Last

AMETEK
TEST & CALIBRATION INSTRUMENTS

Newage | Versitron®
hardness testing

Name: **Conversion**

Hardness Scale: **HRC**

Time at Load: **2 secs** + -

Measurements per Part: **1** + -

High Tol: **None** Off

Low Tol: **None** Off

Conversion: **HRA**

Roundness (Ø): **None**

Save

Cancel

AMETEK
TEST & CALIBRATION INSTRUMENTS

Newage | Versitron®
hardness testing

Name: **NC001325**

Disk Usage: **41%**

DataView: **On**

Export...

Clear Data...

AMETEK
TEST & CALIBRATION INSTRUMENTS

Statistical Analysis

The Versitron features an on-board SPC Software Program. Store 1000s of test results and get an immediate overview of statistics and results.

Test Setup

Select all test settings from one screen. Test settings can be viewed at any time, but modifications can be blocked pending user access level.

File Management

Review, select or export measurement files. Enable automatic export to advanced SPC programs such as DataView.

Useful Functions

- User access levels to prevent unauthorized tampering of presets
- USB output for transfer to DataView and other data collection devices
- Load Lock feature to ensure the correct test load is applied
- Minimum thickness calculation

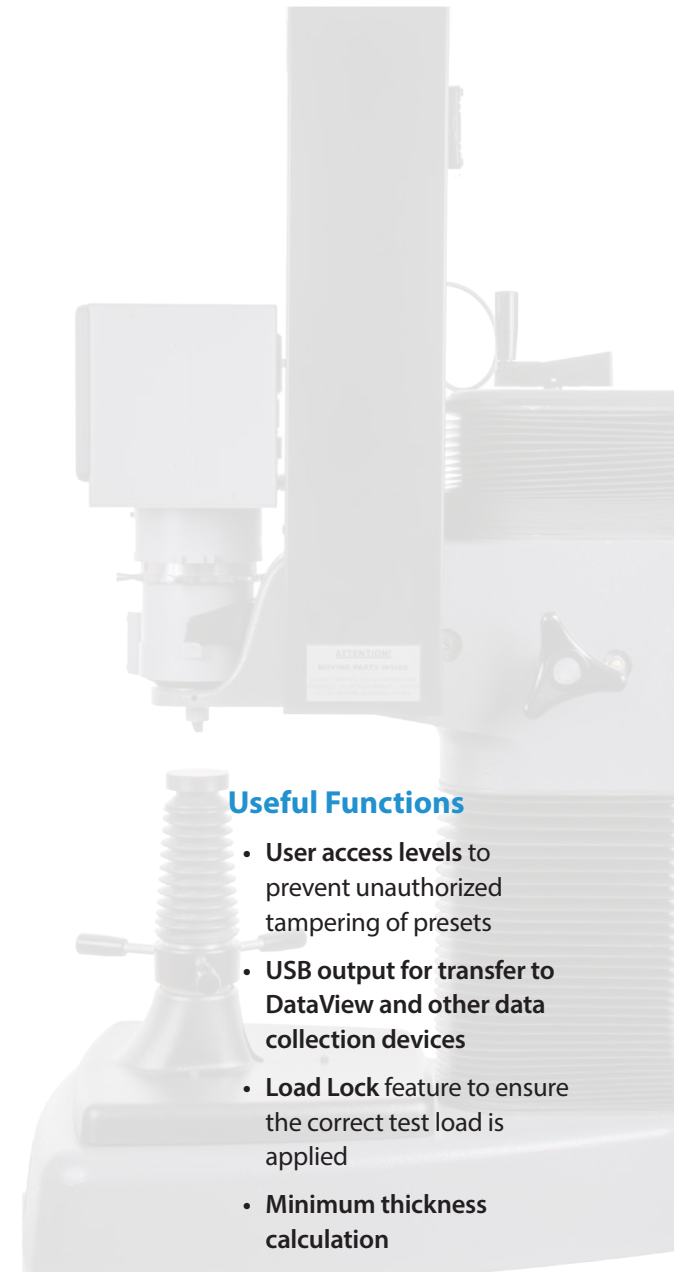

DataView[®] Software

Seamless Integration

Results are transmitted from the hardness tester to PC for data analysis and documentation.

Comprehensive Documentation

Direct export of test data to Microsoft Excel or other OLE-2-compatible files.

Security

Secure access using USB key.

Flexibility

Upload test data from any digital tester upon request or automatically.

Customizable

Up to ten user definable fields can be created to save data with measured results.

Powerful Analysis

Average, Min/Max, Range, Std Dev, CpK, LcL, UcL.

Easy Reporting and Analysis

DataView allows various graphical printouts to be selected including Xbar R charts, results lists and histograms.

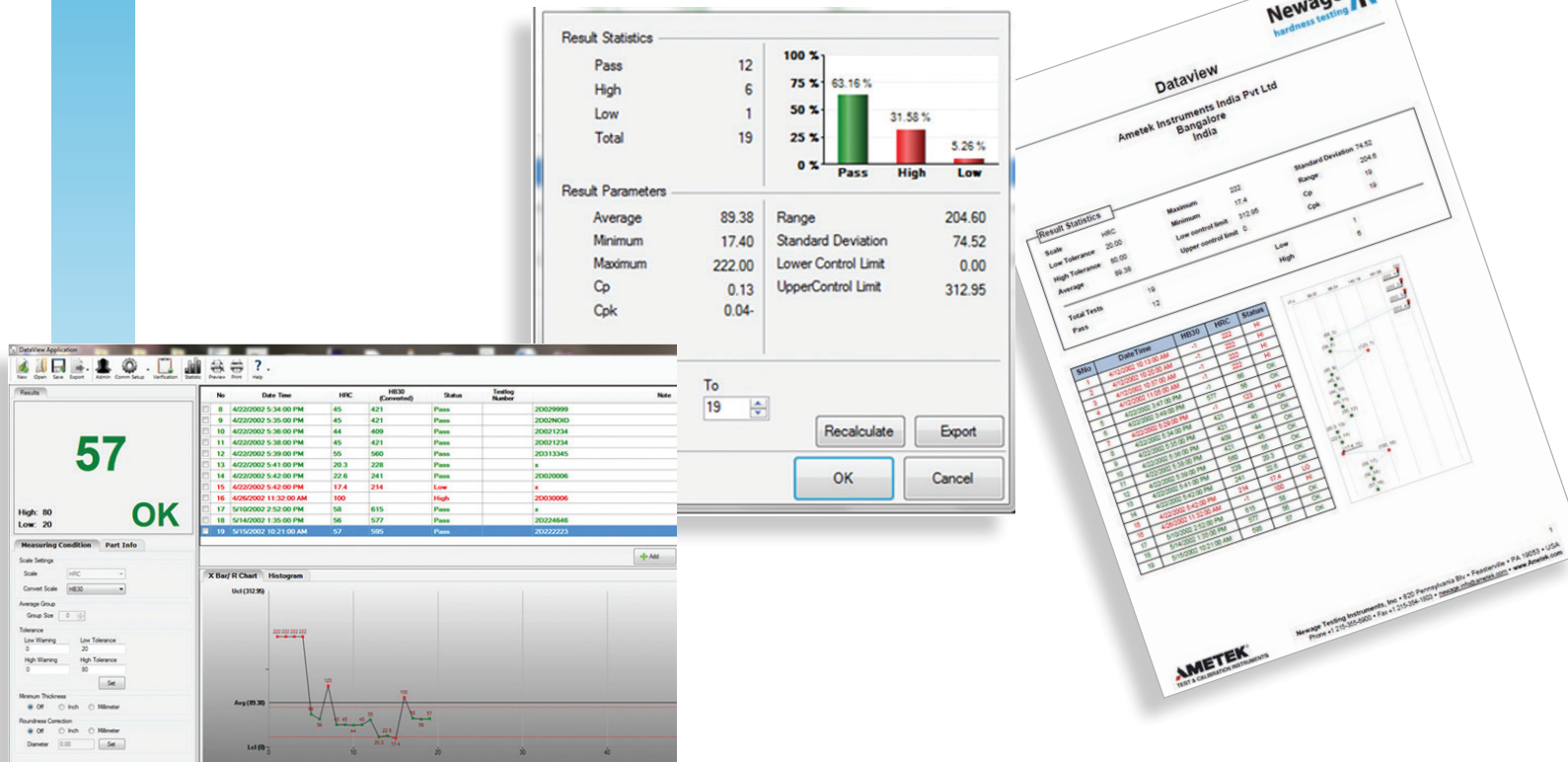

DataView software is an easy-to-use data acquisition utility that is compatible with all Newage or competitive hardness testers having an RS232 serial data output and capable of ASCII transmission. DataView is designed to enhance the capabilities of hardness testers by allowing you to transfer test results directly to a PC for real time, on-screen data management.

Specifications

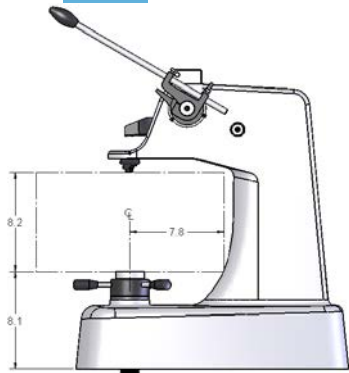

AT130N frame and manual lever

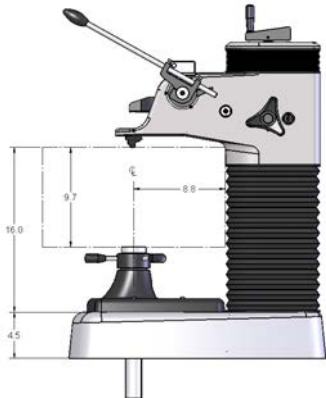

AT130T frame and manual lever

Test Heads	BT130R	BT130S
Standards Compliance	Exceeds ASTM E18, DIN, EN, ISO and other applicable national and international standards	
Rockwell Method	Regular	Superficial
Major Loads	60, 100 & 150 kgf	15, 30 & 45 kgf
Preload	10 kgf	3 kgf
Test Scales	A, B, C, D, E, F, G, H, K, L, M, P, R, S, V	15N, 30N, 45N, 15T, 30T, 45T, 15W, 30W, 45W, 15X, 30X, 45X
Test Blocks (incl.)	C & B	30N & 30T
Test results in memory	9999	
Time @ load setting user selectable	0-99 sec	
Data Output	USB via an RS-232 to USB Converter	
Power requirement	115/230VAC, 50-60Hz	
Included in delivery	Certified diamond indenter, 1/16" Tungsten carbide certified ball indenter and two certified test blocks	

* The interchangeable regular and superficial test heads can be ordered as using part no. BT1302RS, which includes both BT130R and BT130S

Test Frames	AT130N	AT130T
Vertical Capacity	208 mm/8.2 in	246 mm/9.7 in
Vertical Capacity without anvil stage	N/A	406 mm/16 in
Optional Vertical Capacity*	N/A	Up to 914 mm/36 in
Throat depth	198 mm/7.8 in	224 mm/8.8 in
Clamping Capacity	325 Nm/240 lbf.ft	325 Nm/240 lbf.ft
Dimension	See drawing	See drawing
Weight	63.5 kg/140 lb	120 kg/266 lb
Drive Options for Frames		
Manual lever	Standard	Standard
Electric drive	AT130MT2-N	AT130MT2-T
Included in delivery	2" flat anvil, spot anvil, two vee anvils, vinyl dust cover and set of Allen wrenches	

* AT130T-28 (28 inch capacity) and AT130T-36 (36 inch capacity)



Versitron® Rockwell Tester (230VAC version) conforms to relevant EU standards and is CE marked

Anvils & Accessories

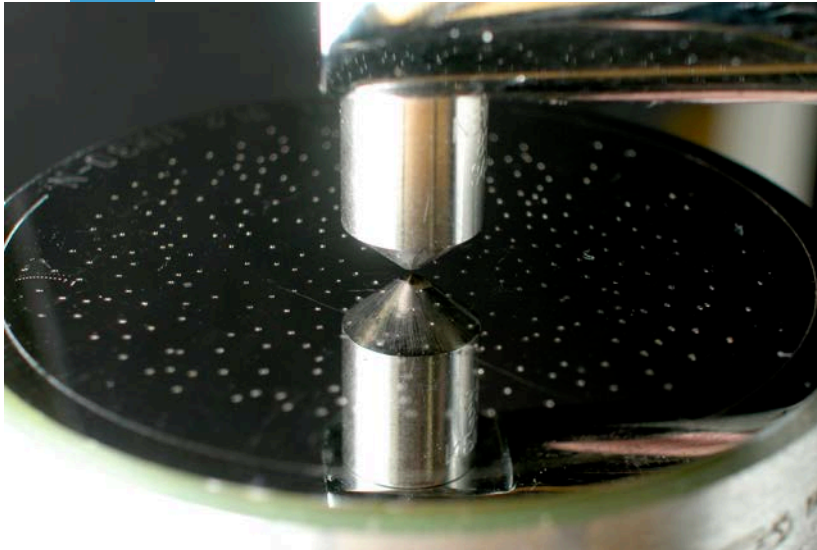

AT/5309 Diamond Spot Anvil	Provides controlled deformation for testing soft or thin metals where the anvil effect is assumed.
AT/5310 2" Diameter Flat Anvil	For testing of parallel face specimens.
AT/5311 Spot Anvil	For testing against small areas or confined spaces.
AT/5312 Shallow Vee Anvil	For testing small cylindrical specimens.
AT/5313 Wide Vee Anvil	For testing cylindrical specimens.
AT/5318 Set of 3 Small Anvils	For small parts testing. Includes flat, spot, and round anvils and anvil adapter.
AT/5319 Flattened Vee Ball Anvil	Test parts with tapered or non-parallel faces can be tested quickly and accurately with this anvil. The flat face is rotated to take up the taper on the underside of the test piece, while the test surface is clamped perpendicular to the indenter.
AT5319V Flattened Ball Anvil	with vee for testing tapered rounds.
AT/5322 Anvil Adapter to fit 3/4" post diameter anvils	Standard or special anvils built for conventional hardness testers can be adapted to the Versitron® by reducing the spindle hole diameter.
AT/5510 Flexible Arm Electric Light	With on-off switch, holding fixture, 115V transformer, and a power cord.
AT/5535 Audible Alarm	A loud signal for out-of-tolerance conditions. For DS model test heads only. (Must be ordered at time of test head purchase.)
9011 8" Anvil Table	Circular 8" dia. work surface to support large test pieces
9012 Jominy Test Fixture	Enables end quench testing at specified intervals along the axis of a Jominy test piece. The test specimen is securely held in proper alignment. The hand wheel controls test positioning. The base is graduated at 1/16" or 1 mm intervals, specify with order.
AT/5620 Vinyl Protective Cover	
AT/5324 Adjustable Cylinder Vee Anvil	With two positions.
AT130B Floor Cabinet	To mount any bench model. A hole is drilled for the elevating screw. Includes an area for test blocks, anvils, etc.

We have a complete range of test blocks available - [see more here](#)

Indenters

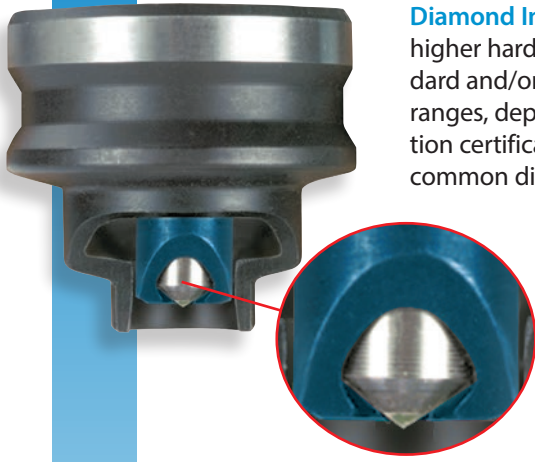

*Indenter and standard shroud
(in false color) shown in normal
operating position with the standard
clamping shield*

Diamond Indenters are used on higher hardness metals in the standard and/or superficial hardness ranges, depending on their calibration certificates. C scale is the most common diamond scale

Ball Indenters are used on softer metals in the standard and/or superficial hardness ranges, depending on their calibration certificates. Larger balls are used on softer materials.



Certified Diamond Indenters

- AT/5110-07 - C scale
- AT/5103-07 - C and A scales
- AT/5109-07 - All superficial N scale
- AT/5107-07 - Tapered C, A, or D scales, use with shroud AT/5404
- AT/5106-07 - Tapered N scale, use with shroud AT/5404



Ball Indenters

- AT/5111W-07 - 1/16" Tungsten carbide ball; B, F, G, and T scales
- AT/5112W-07 - 1/8" Tungsten carbide ball; E, H, K, and W scales
- AT/5113W-07 - 1/4" Tungsten carbide ball; L, M, P, and X scales

Diamond Indenters are carefully checked and double-checked to verify compliance with ASTM and international specifications. These diamond indenters are marked with Newage name, part and serial numbers. The supplied certificate lists the scales and test results from calibration.

Indenter Shrouds



Indenter and standard shroud (in false color) shown in normal operating position with the standard clamping shield

Standard shrouds are used in most applications. They are cut away on one side to provide visibility of the indenter contact point, and apply a 3/8" contact area on the workpiece.

Enclosed Indenter Shrouds are used in automatic testing applications or manual applications where standard shrouds prove inadequate.

Double Taper Shrouds are used in applications requiring a narrow contact area with the workpiece (.085" minimum) or requiring full visibility of the indenter contact point. Double Taper Shrouds are not normally used with a clamping shield.

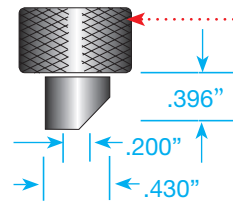

AT/5401 Standard – use with clamping shields 5416, 5320, 5321 and all indenters except 5106 & 5107 (Included with all test heads)

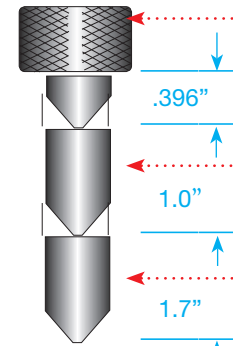

AT/5406 Double Taper* – use with any indenter except 5106 & 5107

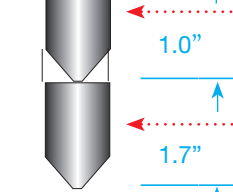

AT/5415, 1" Extended Double Taper* – use with any indenter except 5106 & 5107



AT/5414, 1.7" Extended Double Taper* – use with any indenter except 5106 & 5107

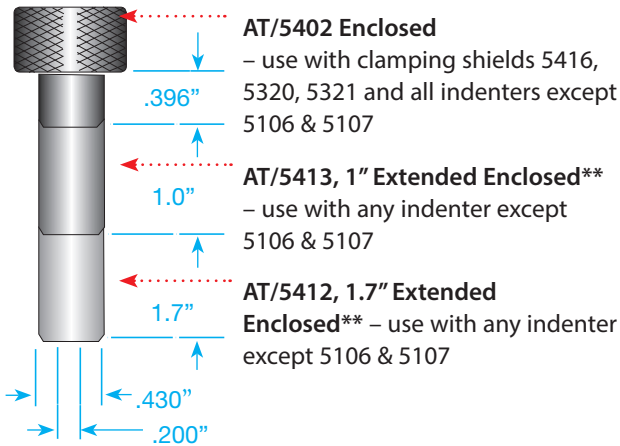

AT/5402 Enclosed – use with clamping shields 5416, 5320, 5321 and all indenters except 5106 & 5107

AT/5413, 1" Extended Enclosed** – use with any indenter except 5106 & 5107

AT/5412, 1.7" Extended Enclosed** – use with any indenter except 5106 & 5107

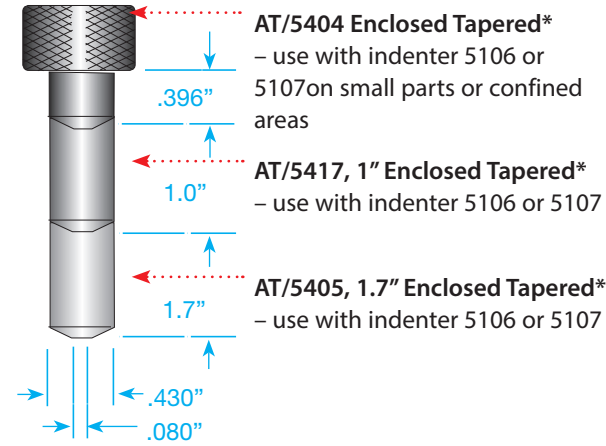

AT/5404 Enclosed Tapered* – use with indenter 5106 or 5107 on small parts or confined areas

AT/5417, 1" Enclosed Tapered* – use with indenter 5106 or 5107

AT/5405, 1.7" Enclosed Tapered* – use with indenter 5106 or 5107

* Not normally used with a clamping shield.

** Part of a package that also includes an indenter extension and an extended enclosed clamping shield.

Indenter Shrouds are an integral part of the Test-Surface Reference feature and must always be used in all testing. The standard shroud has a cutaway for a better view of the test location.

Clamping Shields



Indenter and standard shroud (in false color) shown in normal operating position with the standard clamping shield

Standard Clamping Shields are cut away on one side to provide visibility of the indenter contact point while providing some protection of the diamond from possible damage.

Enclosed Clamping Shields provide total indenter protection. They are used in circumstances where standard shields are inadequate.

Shortened Enclosed Clamping Shields provide total indenter protection in automatic applications.

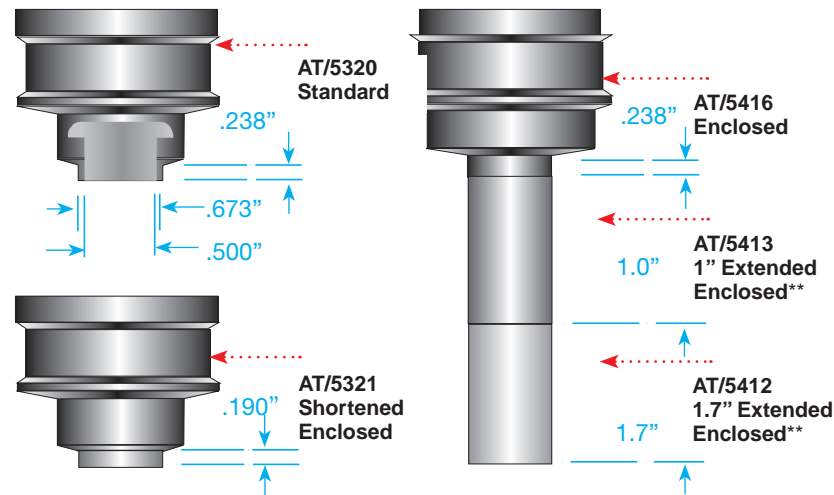

** Part of a package that also includes an indenter extension and an extended enclosed shroud.

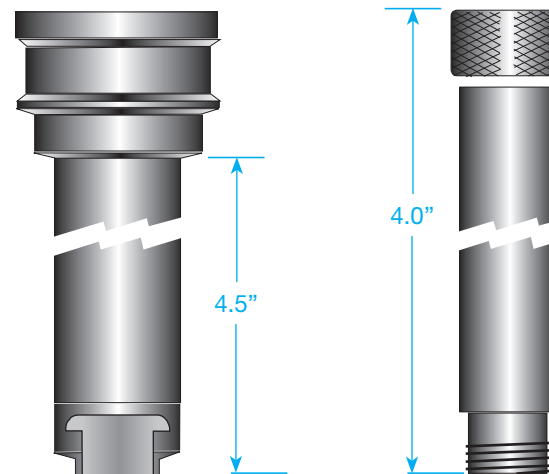

AT/5411 4" Extension Package – includes extended clamping shield with extensions for shroud and indenter. Used with any standard length shroud.

Clamping Shields are used in many applications but are not required for testing and are not part of the test cycle. They attach to the test frame - not the test head. All clamping shields can be easily snapped in or out without tools.

Customization

Newage Testing Instruments has been providing its customers with the benefit of its vast experience in the area of design and construction of Rockwell, Brinell and Microhardness testing systems for over 60 years. We have produced standard and custom systems for major manufacturers and government agencies covering virtually every type of industry base imaginable. Many of these systems, in continuous use and operation, are a true testament of the reliability and longevity that are design features of every Newage Custom and Automatic Test System. The photos illustrate some of our capabilities and achievements in these areas.



USA, Pennsylvania
Tel +1 (215) 355 6900
newage.info@ametek.com

USA, California
Tel +1 (800) 444 1850
sales@crystalengineering.net

India
Tel +91 22 2836 4750
ametekdk@ametek.com

Singapore
Tel +65 6484 2388
ametekdk@ametek.com

China, Shanghai
Tel +86 21 5868 5111
lloyd@ametek.com.cn

China, Beijing
Tel +86 10 8526 2111
lloyd@ametek.com.cn

United Kingdom
Tel +44 (0)1243 833 370
uk-far.general@ametek.co.uk

France
Tel +33 (0)1 30 68 89 40
general.lloyd-instruments@ametek.fr

Germany
Tel +49 (0)2159 9136 510
info.mct-de@ametek.de

Denmark
Tel +45 4816 8000
ametekdk@ametek.com

Safe & Reliable

Newage bench-style Rockwell scale hardness testers meet ASTM E18 for Rockwell hardness testing.

Newage Testing Instruments also offers calibration service which is accredited to A2LA.



Z-CHECK
CORPORATION

35560 Grand River Ave, #420
Farmington Hills, MI 48335
P: 248-676-1007 / E: sales@z-checkcorp.com
Website: www.z-checkcorp.com

© 2015 AMETEK Inc.

Pub code: SS-Versitron Issue: 1505

Information in this documents is subject to change without notice. No part of this document may be reproduced or modified in any form or by any means, electronic or mechanical, without express written permission from AMETEK Test & Calibration Instruments.

Newage
hardness testing

www.hardnesstesters.com

AMETEK
TEST & CALIBRATION INSTRUMENTS