



eddyvisor[®] digital

Digital eddy current test instrument for nondestructive testing of components, mass produced parts and semi-finished products for cracks, pores and grinder burn using Preventive Multi-Filter Technology and for material properties such as hardness, case depth, structure, tensile strength, heat treatment or alloy using Preventive Multi-Frequency Technology.

High power modular instrument concept with max. 16 independent crack detection channels, max. 32 structure test channels and their combinations.



The eddyvisor distinguishes itself with its high performance modular concept with max. 16 independently working crack detection channels and max. 32 structure test channels all in a very compact design. Additionally, it offers unique features for the realization of sophisticated test tasks using the eddy current technique, combining that with the well known ibg test reliability and ease of operation.

The ergonomic interface enables easy and simple operation via touch screen. All functions and test results are captured at a glance. Digital processing of the measuring signal with unique processors, immediately after the pre-amplifier guarantees the greatest possible stability of test results.

The eddyvisor is based on the long proven ibg system concept. All coils, probes, rotating heads and other system components are standardized worldwide. So eddyvisor is the solution for new tasks and to upgrade existing production machines to equip them with state of the art eddy current technology.

In the field of crack and grinder burn detection, the need for trained experts to perform the sophisticated and time consuming tasks of manual determination and setting of suitable filter band, phase angle and gain is eliminated by ibg's exclusively developed Preventive Multi-Filter Technology (PMFT), which automatically creates tolerance zones by simply scanning good parts. This quantum leap in eddy current technology, unique

to ibg worldwide, establishes a new standard for quality in crack and grinder burn detection by the eddy current method.

During material data recording (calibration) with PMFT, surface areas of several good parts are scanned. The good surface eddy current "noise" is recorded simultaneously in each of 30 band pass filters. Tolerance zones, enveloping 360 degrees, are automatically created within each filter band, capturing the allowable eddy current "noise" from good parts. Good part noise signals result from allowable variations in surface roughness and material properties. Thus, the thirty tolerance zones store the part specific fingerprint of the good parts. Edge effects, hardness profile run out, eccentricity, etc. of the good parts are calibrated during material data recording. Thus, pseudo rejects are reduced considerably without losing visibility to real flaws.

The unique "good-part-only-concept" enables setup within a few minutes. Simply scan and record an adequate number of good parts. Tolerance zones within each of the 30 PMFT filter bands are automatically generated capturing the allowable noise from the good parts to form good part finger prints in each of the 30 PMFT filter bands. After material data recording, one key press switches to Preventive Multi-Filter Test, and the test can start. Done! Faster starting yet more reliable eddy current testing is not possible.

Crack and grinder burn detection

Efforts to reduce content of valuable raw materials and of energy bring reduced cross sections in high volume components in the fields of mechanical engineering and automobile components. The resulting reduced cross sections and stricter material properties requirements have incentivized manufacturers to guarantee correct structure and crack and grinder burn free condition by increased nondestructive testing.

The eddy current test method can be applied for all materials with electrical conductivity or magnetic conductivity (permeability). This includes all metallic materials. The eddy current crack and grinder burn test can be adapted to many test tasks by selecting the suitable crack detection probe and transmitter frequency. As a matter of principle, mainly surface open or flaws close to surface and pores are detected.

The test resolution and effective scan width of a crack detection probe is dependent on core size and type (between 0.5 and 5.0 mm). When testing, a relative movement of probe to surface of test part is always required. In order to test rotationally symmetrical parts for cracks, either the test part is rotated and the probe stands still or the test part stands still and the probe is rotated around the part by means of a rotating head. If more than one line shall be tested additional feed forward is needed. Thus complete surfaces can be scan-



Crack detection probe box for contacting testing on eccentric parts like camshaft lobes for cracks and grinder burn; large diameter range is covered; up to 300 rpm (depending of part geometry), ceramic supports for long life-time. Solutions for structure test on camshafts on request.

ned. More complicated surfaces require more complicated mechanical handling systems. Our own special machine manufacturing group is always pleased to work with you to design and build a test system for your 100 % testing.

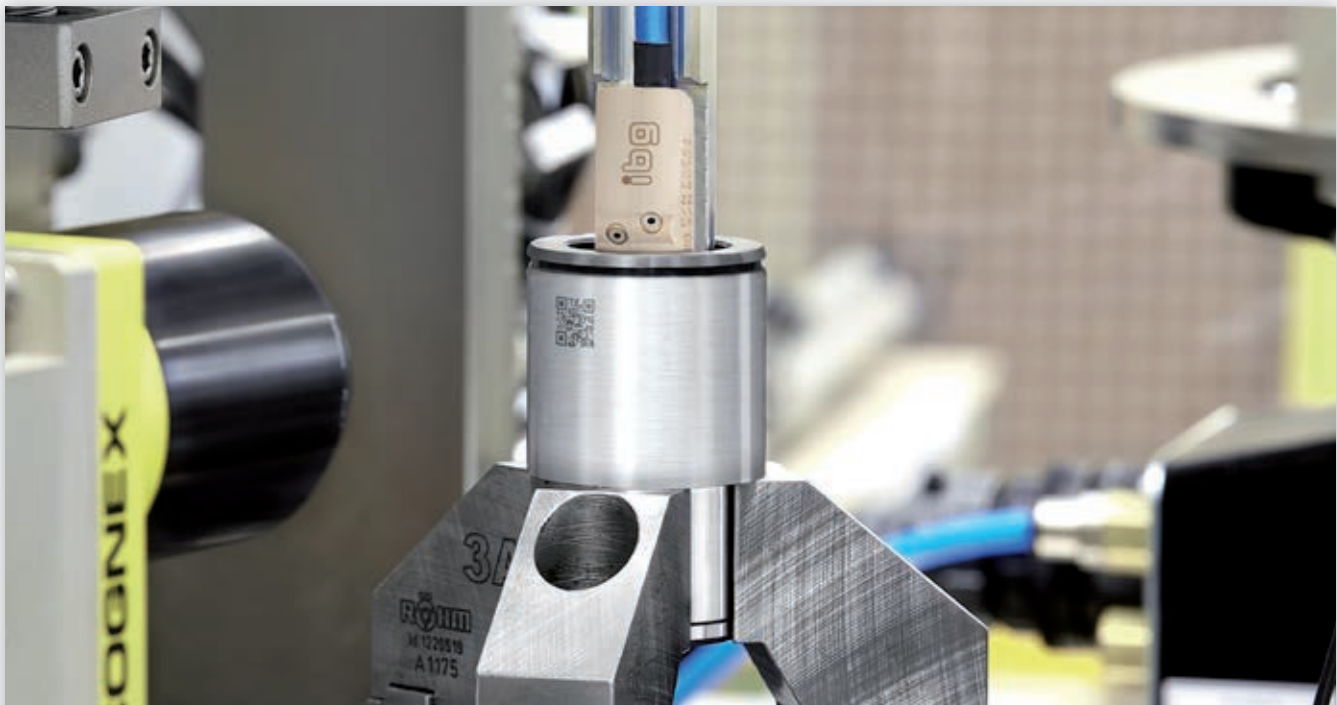

Steering nut in an automatic ibg test system. Detection of cracks and grinder burn defects on the race inside. With camera inspection system to capture part type specific QR-code.

In the past the eddy current crack test would be set to optimally detect an artificially generated (EDM) defect master. But artificial defect masters show different eddy current behaviour (i.e., phase shift, etc.) than natural defects. Thus, natural defects could go undetected. Now the ibg technique with its eddyvisor instrument family walks on new paths. Thanks to the Preventive Multi-Filter Technology the instrument is not set to an artificial defect anymore but to the eddy current pattern of “healthy” surfaces of several OK parts. Automatically 30 tolerance zones over the entire spectrum of filter bands are formed which in fact picture the “healthy” surfaces in the test instrument. As soon as one of these tolerance zones are exceeded by the eddy current signal a NG signal is triggered, no matter if caused by an artificial or by a natural defect.

For proof of test sensitivity, an artificial defect is put into an OK part by EDM processes. This defect must be 100 % detected by the instrument for validation of the method and of the test system. The limit defect of your application is determined beforehand in our lab during a feasibility study. It results in definition of direction and dimension of the smallest reproducible defect that must be 100 % detected without or without significant pseudo rejects.

The well-known note “surface to be free from cracks” on drawings suggests a wish for perfection of the part to be produced. However, there are physical limits of the eddy

current crack detection relative to that wish. We have committed ourselves to move these limits further in the direction of smaller, detectable “discontinuities” without increases in pseudo rejects and under production conditions. The exploitable sensitivity of the eddy current crack test depends on several parameters:

- Surface roughness - detection of small defects is better the smoother the surface is. The limit is at defect depth equal to 5 times roughness depth, but not less than 50 µm.
- Material - use of differential probes generally suppresses noise inherent to different materials. But the material tested is a factor. For example, the detection limit for lamellar cast iron can increase to approx. 150 µm due to carbon needles in this material.
- Distance probe to surface - increasing probe distance reduces sensitivity, while decreasing probe distance enhance sensitivity to surface roughness and eccentricity of the test part. A good compromise for most applications is the ibg standard probe distance of 0.7 mm.
- Direction of defects - the direction of a defect relative to the probe trace direction also influences the test sensitivity. This can be influenced by choosing the suitable ibg probe system.

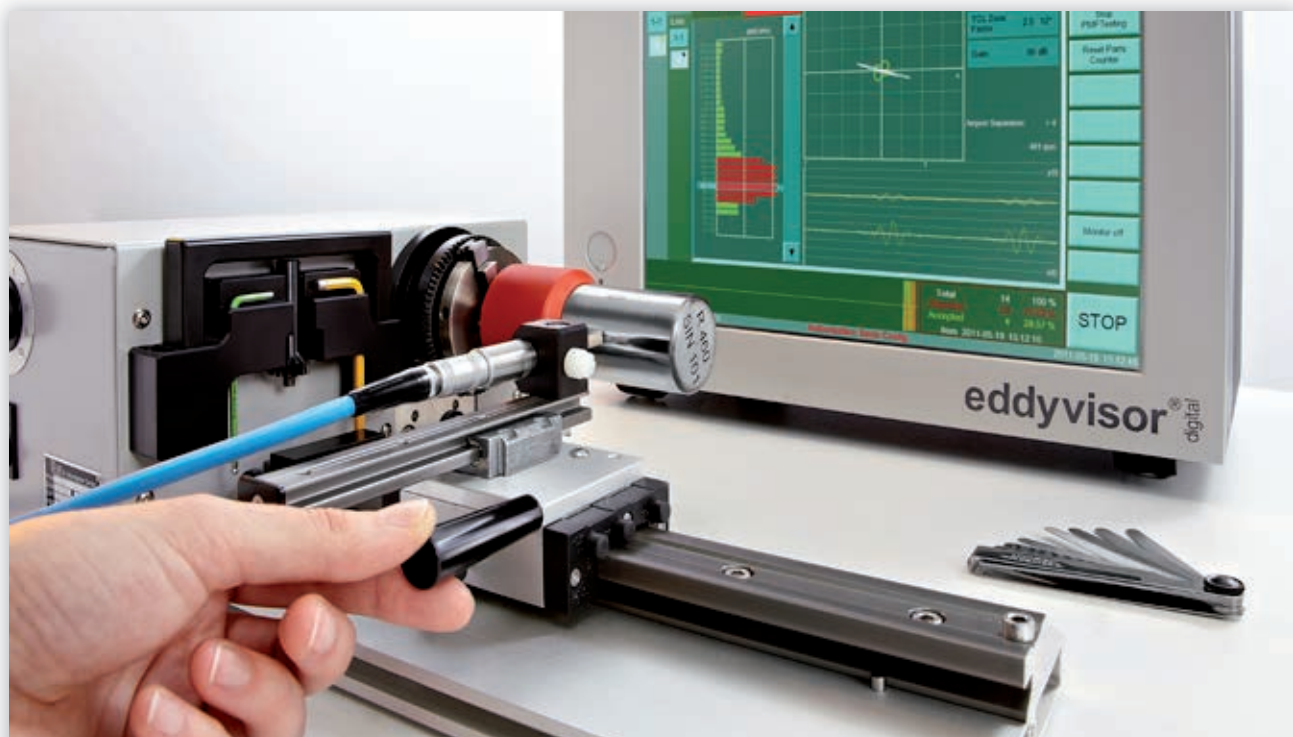

ibg lathe for lab tests, feasibility studies and small series in crack detection with eddyvisor. Speed max. 850 rpm, chuck up to 68 mm diameter, with trigger sensor, flexible probe movement.

ibg mainly applies differential probes for crack detection. The differential principle reduces the very large receiver signal almost to zero by use of two compensating counter rotating receiver windings. This enables very high amplification of very small signals from flaws without overloading the input of the test instrument. Furthermore, ibg places high standards for precision for its own probe manufacturing, further enabling higher amplifications. On the noise side, ibg instruments employ extremely low noise signal processing, earliest possible digitalization and smart signal processes. Thus, ibg is able to combine very high flaw signal amplification with very low noise signal processing allowing larger distances between test probe and test surface without loss of test sensitivity. The advantage realized is that ibg test probes can be held 0.7 mm off of tested surfaces without sacrifice of test sensitivity and test resolution. The small flaws are detected. Other manufacturers only guarantee similar sensitivity with 0.2 - 0.3 mm probe distance. But probes so close see more good part noise, and there are more pseudo rejects of good parts. In general, differential probes are highly sensitive for local surface defects. They are also relatively immune to variations in test part

structure such as different batches, allowable heat treat variations, etc. These characteristics are important for avoidance of pseudo rejects when doing 100 % testing.

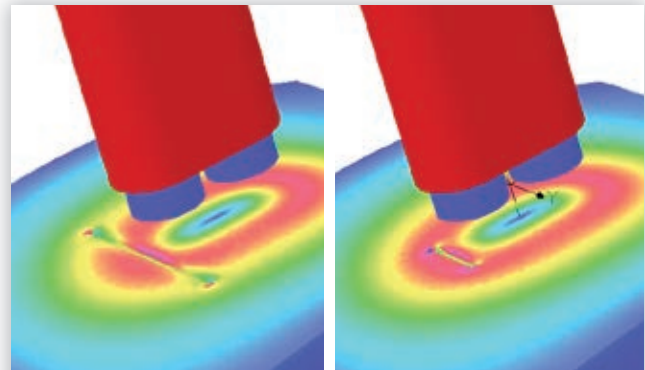

Simulation of the eddy current density generated by a differential probe on the surface of a roller. It shows disruption of the eddy current caused by an EDM crack as detected by a crack detection probe. Left: typical Spec crack with 3 x 0,1 x 0,1 mm. Right: same crack, but with a length of only 1 mm.

Grinder burn detection

As per ISO 14104, grinder burn is a local overheating of surfaces. Heat impact during the grinding process was too much and effected localized annealing or, if heat impact was still stronger, there can be re-hardening zones. Depending on part surface quality and geometric influences, the ibg PMFT detects grinder burn with detection beginning at the level of mere change in residual stress or beginning of annealing zones in the microstructure.

A method applied by ibg to produce reference samples for grinder burn detection is laser burn: heat, defined and locally applied to the surface of the test part. Thus, producing defined artificial defects of different intensity in metallic parts which show analogue features like real damage. They can widely be produced and reproduced at defined spots according to requirements (kind and depth of structure change, spacial dimension) and they

serve as master part for validation of automatic test machine as well as for determination of sensitivity of a test system.



ibg crack and grinder burn master with EDM cracks and pores for simulation of surface open defects and with laser defects for simulation of grinder burn; intensity mere residual stress (cutting far left) and beginning annealing zone (left).

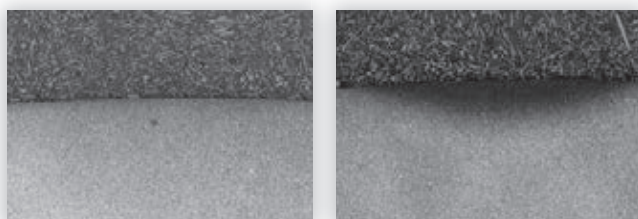

Product features crack and grinder burn detection

- **Probes**

A selection of probes for crack detection is available which vary in trace width, sensitivity and shape. Customised probes for special applications are designed and manufactured in house. Compact and highly precise ibg rotating heads eddyscan H and eddyscan F are available, in many cases installed for optimization of cycle time. They work together with the test instrument eddyvisor. Cable break monitoring offers high security in continuous operation.

- **Probe distance**

ibg probes are by default manufactured for a large probe/part distance of 0.7 mm. Thus, demands on part exactness and test mechanic are relaxed considerably.

- **Lift-off compensation**

If a part is very eccentric, the distance of probe to test part may be additionally balanced electronically by use of the optional lift-off compensation. Special lift-off compensation probes are supplied for this function.

- **Suspend**

The suspend function blanks out areas not to be tested like holes or similar.

- **Displays**

Display of test results as bargraph, xy-diagram with tolerance zones and x(t) and y(t) or three-dimensional C-scan display can be selected. The C-scan (or waterfall diagram) is a rotationally synchronized display of test signal from part circumference enabling local allocation of defects on the surface.

- **Frequency range**

The carrier frequency is selectable within a range of 3 kHz to 10 MHz in 21 steps. The filter frequencies of the 30 band pass filters distribute in the range of 6 Hz to 20 kHz.

- **Trigger of test**

Manually on the instrument, via PLC or by optional start button.



Highest test reliability and sensitivity - different kinds of probes for crack and grinder burn detection. Back left a rotating head eddyscan H for testing a string of parts and bars, back right a rotating head eddyscan F for testing of boreholes and surfaces.

Crack detection of a wheel hub at six locations on inside and outside. Each location has its own reference data generated from good parts. View of the test areas and their results colour highlighted on the screen.

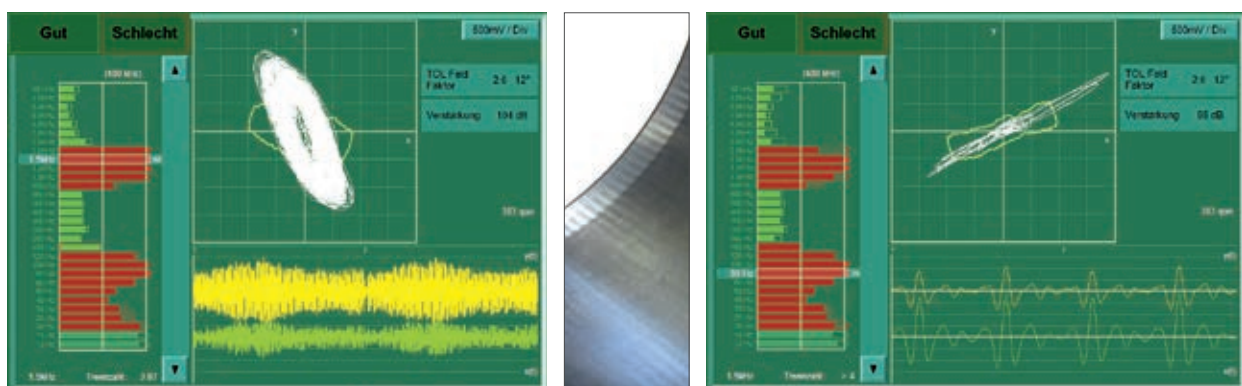
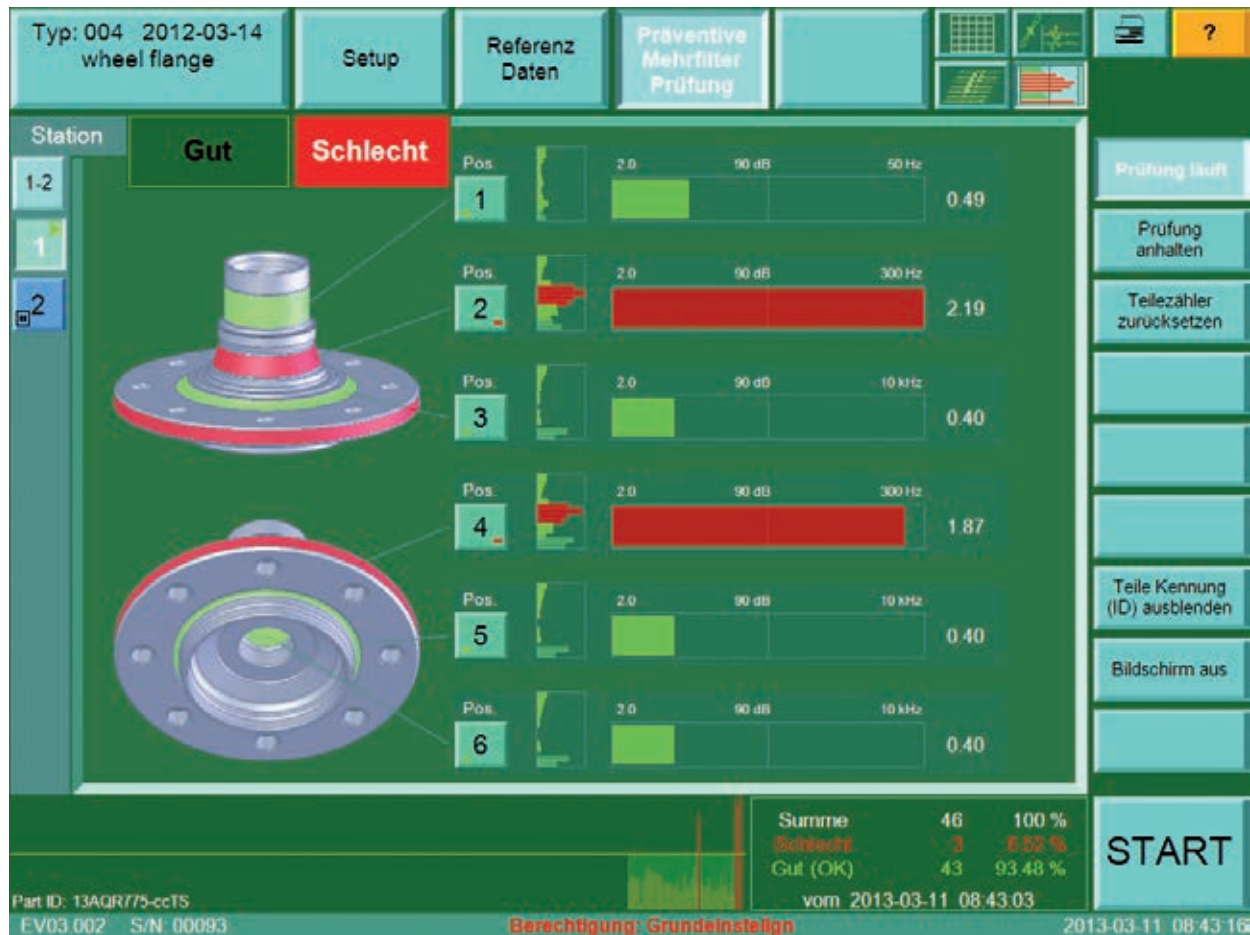

Left: eddy current signals from grinder burn chatter is detected in a high filter frequency range. Test is on bearing ring.

Right: signals of the same test on the same bearing ring but in a lower filter frequency range detect additional grinder burn signals at two opposite locations on part circumference. These signals are due to grinder burn caused by ovality of the inner diameter. Due to the Preventive Multi-Filter Technology with 30 simultaneously working band pass filters, unexpected as well as expected defects are detected. Such unexpected defects would be passed as OK by conventional instruments with only one frequency band.

Structure test

A difficult problem for in process inspection of mass parts is supervision of heat treatment results. Verification of features like correct case depth and hardness are of prime importance for meeting the quality standards of the final product. These features can be monitored by destructive methods like sampling but with concurrent high personnel and financial effort. Moreover, a sampling inspection is sensible for statistically distributed defects only. During heat treat processes in furnaces or induction hardening, accidents involving single parts and that violate statistical distribution laws happen. These “unexpected” defects can be missed by sampling. 100% testing is required to reliably detect them.

Eddy current structure test utilizing the well known Preventive Multi-Frequency Technology (PMFT) by ibg guarantees maximum test reliability in 100 % testing. Heat treatment results in serial testing can be monitored cost efficiently, quickly and reliably, and unexpected defects are detected with highest reliability. The eight test frequencies of the fundamental wave as well as analysis of two harmonics of the PMFT guarantee highest reliability. The field of application for PMFT with simultaneous harmonic analysis is very wide and includes testing surface hardness, case depth, intermediate structure, material mix-up and others.

Setting of the instrument is done with good parts only. Ten to 20 parts are presented to the instrument, and tolerance zones are formed automatically. Eddy current signals from subsequent parts are now compared with these good parts. That means that no artificial defects are required for calibration, only known good parts. Due to the high test speed and the easy setup a new test task is ready to start within shortest time. Another advantage is the multi-dimensional analysis of ibg test instruments. An individual tolerance zone is formed for each test frequency. If all tolerance zones are satisfied, one can assume that the tested part is okay. Even one single not satisfied tolerance zone classifies the part as not good.

Eddy current tests are always comparative tests with yes/no answer. Very small deviations in the group of parts can be detected. Eddy current cannot answer why there is a deviation. In case of a bad part another test is recommended like metallurgical methods to inspect the structure (cut) or a classic hardness test.



Fixture for manual eddy current structure test in the lab.



Simultaneous Harmonic Analysis iSHA

The relative permeability is strongly influenced by heat treatment processes. Hardened structures have a lower permeability than soft structures. Because the ibg Preventive Multi-Frequency Technology PMFT tests with small magnetic fields hardened OK parts show no saturation effects. It is within the linear range of the hysteresis curve.

Harmonics occur by each hysteresis of the magnetisation curve of a test part in the coil arrangement. The sinusoidal current in the exciter coil leads to a sinusoidal field strength which induces a magnetic flux in the test part. Its chronological sequence, however, is (depending on formation of permeability) not sinusoidal anymore. Therefore the chronological sequence of the magnetic flux in the receiver coil induces a distorted voltage, deviating from the real sine even at small field strengths.

The fundamental waves, having been distorted by hysteresis, contain higher frequency harmonics. Fourier analysis (FFT) of the distorted fundamental waves reveals the higher frequency harmonics, more precisely harmonics of the 3, 5, 7 or 9 times frequency. The analysis of these harmonics supplies a more detailed view of the magnetic features of the test part and thus more exact information on the formation of microstructure. In addition, it offers significant advantages when suppressing interferences like batch scattering, part geometry and part temperature or positioning effects. Harmonic signals are very small. That's why immense electronic effort is needed in order to distinguish them at all from the basic noise and to display them. Such small signals can be detected clearly and processed robustly by ibg's unique and innovative digital eddyvisor instrument family in which the signals are digitized directly

after the pre-amplifier and are processed by extremely fast DSP. An essential innovation is iSHA (ibg's Simultaneous Harmonic Analysis) iSHA combined with ibg's PMFT guarantees highest possible test reliability. It enables simultaneous calculation of vectors of the fundamental wave at eight frequencies and of two harmonics without extension of test time. It additionally uses high frequencies and their harmonics for a better solution of even smallest structure differences. Thus iSHA greatly enlarges the possibilities of the well-known Preventive Multi-Frequency Technology (PMFT).

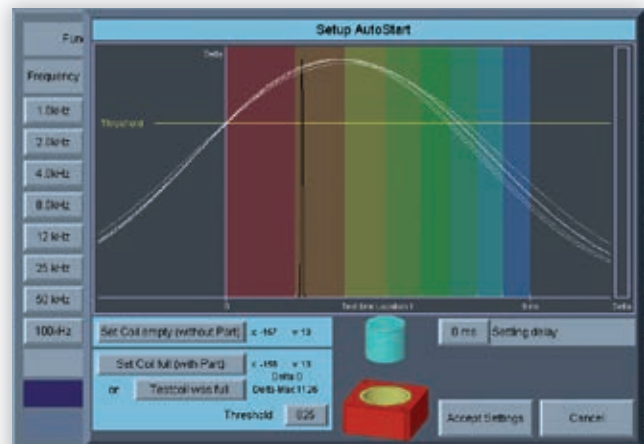

New: the rapid AutoStart enables a much speedier and more precise automatic triggering than up to now. An additional graphic display eases the setting significant also for fast or dynamic tests.

Features of structure test

- **Tolerance zones**

During material data recording the eddyvisor automatically generates elliptic tolerance zones calculated for reliable testing. A tolerance zone editor is integrated for special situations in the structure test field, a skilful operator may freestyle the fields as rectangle, or ellipse, reduced or expanded, rotated or moved, etc.

- **iSHA harmonics analysis**

Eight test frequencies of the fundamental wave plus two harmonics (2nd to 9th arbitrary) for each of the eight test frequencies can be utilized without extension of test time. The standard setting is evaluation of the 3rd and 5th harmonic on each of the eight fundamental waves.

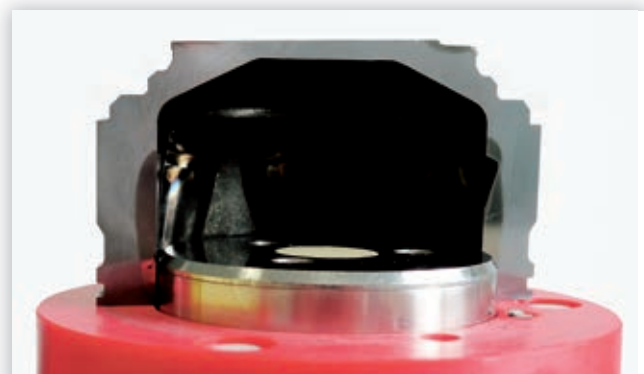

ID coil for structure test on a continuous velocity joint for correct case depth and position of hardness zone.

- **Display**

Display of test results as bargraph diagram, single ellipse or multiple ellipse display selectable.

- **Coils**

A multitude of standard encircling coils up to a diameter of approx. 500 mm and probes for structure test are available for standard applications. Special applications may be solved by custom designed inner diameter I.D. coils or by rectangular coils which are designed and manufactured in house. Monitoring of coil and cable failure as well as 50/60 Hz noise suppression can be activated.

- **Triggering of test**

Start of test can be done manually at touch screen, via PLC or optional start button. There is an auto-start function that detects the part in the test coil and activates testing immediately or after an adjustable delay time.

- **Test frequencies**

Eight frequencies in a range of 5 Hz to 3 MHz are selectable.

- **Test speed**

High speed testing within milliseconds. Using eight test frequencies and standard setting (25 Hz - 25 kHz), 141 milliseconds only are needed for the test. In high speed mode only 1 ms is needed for one test frequency > 5 kHz. This eases above all dynamic tests.

- **Classification**

Sorting of different materials and testing of mixed batches can be accomplished with the ibg classification function (OR-conjunction). Up to seven good part types with different characteristic can be taught and during testing compared to the taught types and classified according to their part type.

- **Bar and tube test (option)**

Bars, tubes and wire can be tested in line to verify material, heat treatment and density differences as well as structure changes. Two proximity switches are used to trigger start and end of test. Nearly the entire bar/tube length is tested. An integrated statistical evaluation of the good versus not good tests (absolute and percentage) is automatically updated. A threshold for an allowable percentage (adjustable) of not good tests can be utilized to eliminate rejects caused by irrelevant local material property variations (e.g. from cold working from handling).



Bargraph display of the latest test result of eight fundamental waves (large) and the third and fifth harmonic (small)

Survey of all test results of eight fundamental waves in the relating tolerance zone

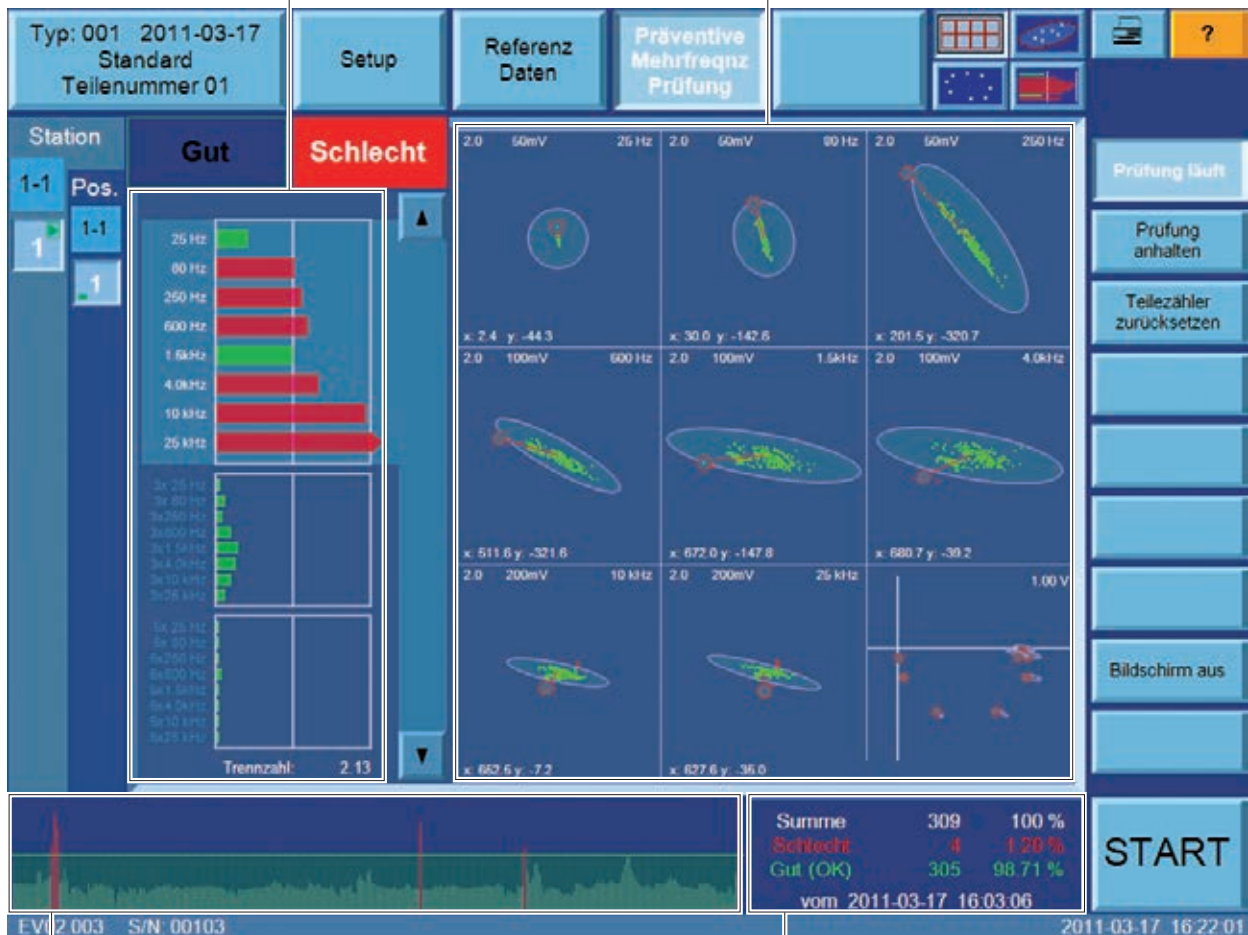

History of test results

Parts counter

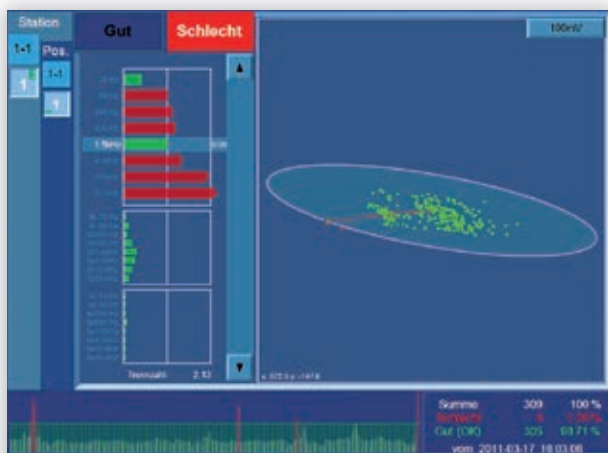

Single ellipse display of all test results at one fundamental wave frequency



Bargraph display of test result

General features

- **Ergonomic design**

All functions and test results including for complex systems are clearly arranged to be viewed at a glance. This enables correct and easy operation even for inexperienced operators.

- **Stations and locations**

The eddyvisor offers a unique station and location concept for solution of complex applications. Maximum eight stations can be defined which may include up to 32 locations. All test locations of one station belong to the same part and are summed up in a station result. This result can be taken for sorting. The part must be tested at all locations of that station in order to get a valid station result. Stations are independent from other stations. Different stations can take different operating conditions. For example, one station can be testing parts, and another station can be recording new calibration data or being adjusted.

In addition, each location has its own set of reference data and tolerance zones. For crack detection, for instance, it is possible to define different areas of a test part (faces, radii, undercuts etc.) and to test each of them with different settings switchable via PLC on the fly. So each area of a test part, including areas with high basic noise (e.g. radii) or with very low basic noise (e.g. high precision machined or super finished surfaces) can be tested with the setting optimised for that area without disturbing testing of the other areas.

- **View of test part**

At stations with at least two and maximum 22 locations a picture of the test part created by customer may be included. The test result of the single locations of the station is visualised by colouration of the test part picture. A huge help for the operator especially in test system with complex setup. These test part pictures can be displayed in the survey of all stations as well (however, w/o colouration of result).

- **Part types**

Maximum 100 part types (at more than eight locations max. 50) in crack detection and max. 250 part types in structure test with all settings and reference data can be stored in the device memory and switched over manually or via PLC for automated processes.

- **Part ID**

Test data for individual parts can be allocated to the part. The eddyvisor can be informed before the test of an alphanumeric serial number from a PLC or another system (QR-code reader or similar). This identity is connected with the related test data, stored in the eddyvisor and additionally written via the eddyLogger Software or as Q-DAS compliant set of data. Indispensable for back tracing individual parts.

		crack channels														
		0	2	4	6	8	10	12	14	16						
structure channels	0	■	■	■	■	■	■	■	■	■	■	■	■	■	■	■
	2	■	■	■	■	■	■	■	■	■	■	■	■	■	■	■
	4	■	■	■	■	■	■	■	■	■	■	■	■	■	■	■
	6	■	■	■	■	■	■	■	■	■	■	■	■	■	■	■
	8	■	■	■	■	■	■	■	■	■	■	■	■	■	■	■
	10	■	■	■	■	■	■	■	■	■	■	■	■	■	■	■
	12	■	■	■	■	■	■	■	■	■	■	■	■	■	■	■
	14	■	■	■	■	■	■	■	■	■	■	■	■	■	■	■
	16	■	■	■	■	■	■	■	■	■	■	■	■	■	■	■
	18	■	■	■	■	■	■	■	■	■	■	■	■	■	■	■
	20	■	■	■	■	■	■	■	■	■	■	■	■	■	■	■
	22	■	■	■	■	■	■	■	■	■	■	■	■	■	■	■
	24	■	■	■	■	■	■	■	■	■	■	■	■	■	■	■
	26	■	■	■	■	■	■	■	■	■	■	■	■	■	■	■
	28	■	■	■	■	■	■	■	■	■	■	■	■	■	■	■
	30	■	■	■	■	■	■	■	■	■	■	■	■	■	■	■
32	■	■	■	■	■	■	■	■	■	■	■	■	■	■	■	

Combination of channels eddyvisor

■ realised with one eddyvisor
 □ a second instrument is required

- **History of reference parts**

The histogram displays the test results of all reference parts at a glance. When after recording of reference parts and afterwards crosschecking in the laboratory it is determined that a part is still not good, it can be removed from the reference parts with one keystroke.

- **History of sorting parts**

The multi-coloured histogram displays the test results of up to 1000 sorted parts and additionally the last 100 bad parts, so they can be observed at a glance and evaluated later. Test results of questionable rejected parts can be recorded as tentative reference parts and later destructively cross checked in the laboratory. If such questionable rejected parts are later found to be good, they can be added to the reference parts with one keystroke. Pseudo rejects can be diminished.

- **AQDEF quality data export
QDAS standard compliant (option)**

Test data are transferred after termination of each test part via Ethernet to a protocol computer where the free eddyLogger Q-DAS software receives the data and provides them AQDEF compliantly to the QS-STAT interface. The software allows the user an individual configuration. The following options are available per test station: selection of data to be stored; storage with K-field or abbreviated separator spelling; memory format as DFD/DFX or DFQ files; free choice of amount of test parts to be stored per file. The eddyLogger software may record and administrate parallel the test data of several ibg instruments within one Ethernet network so that one acquisition computer is able to supervise several eddyvisor and/or eddyliner instruments.

- **Data storage in general**

Test results, part types and instrument settings are stored internally on a tough flash-memory and externally via USB stick. Test results may be additionally logged via network. A ring buffer logfile records all internal failures and allows fast debugging for service purpose.

- **Automation without PLC**

Direct control of sorting devices, paint marking systems or indicating lamps is possible with the integrated 24 Vdc (2.5 amps) power supply, together with the autostart function providing a low cost solution for small automated systems without an additional PLC.

- **Counter preset**

The function "box counter" monitors the filling height of containers to avoid overfilling. Testing is paused automatically as soon as a preset value of tested parts is reached. The operator changes the containers and reset the counter, testing starts again automatically.

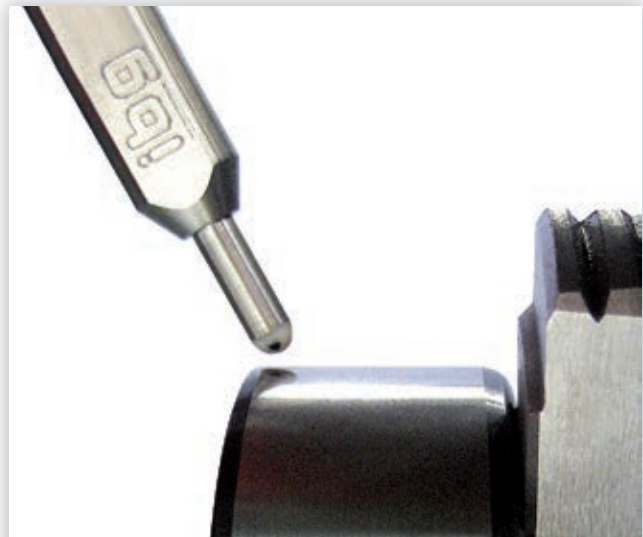

Crack and grinder burn detection on a bearing ring using a spherical X-type differential probe manufactured by ibg.

- **Remote control**

The eddyvisor is remote controlled by each network PC via VNC viewer software.

- **Access protection**

The instrument offers a multi-level access authorisation concept that operates by keyswitch.

- **Help function**

The user always has access to a context sensitive help function on the device screen which often renders a look into the manual unnecessary.

- **Languages**

Included are: German, English, Spanish, French, Italian, Czech, Polish, Portuguese, Chinese, Hungary, Japanese, Korean and Russian. Other languages as option.

- **Screen**

Tough 15" TFT touch screen, colour display, resolution 1024 x 768 pixel, operable with gloves.

Connections

- **IO ports**

An optically insulated interface with 32 in- and 32 out-puts is available for PLC connection. As option, a further module with additional 32 in- and 32 outputs can be installed. An allocation of the signals to the IOs is free in the eddyvisor.

- **Gigabit-Ethernet network**

- **XVGA**

The screen may be displayed on another screen by means of the XVGA-interface. Essential for trainings.

- **Printer**

A usual printer can be connected via USB 2.0 or Ethernet to print screens or protocols.

- **USB 2.0**

Two USB 2.0 ports at the front, one underneath for data storage.

Housing

- Two models of eddyvisor are available: Desktop version eddyvisor D (with retractable feet, inclined) or as separated switch panel version with operating unit eddyvisor HMI and measuring unit eddyvisor M.

- completely sealed and thus suitable for rough production environment.

Technical data

Mains: 100 - 240 V, 50/60 Hz

Ambient temperature: 0 - 45°C

(desktop version 0 - 40°C)

Relative humidity: max. 85 %, non-condensing

Dimensions (w x h x d) / Weight:

eddyvisor D 430 x 335 x 271 mm / 13 kg

eddyvisor HMI 410 x 308 x 96 mm / 6 kg

eddyvisor M 410 x 308 x 175 mm / 7 kg



Rear side eddyvisor, equipped with (from left) crack detection module 4-channel, structure test module 8-channel, IO module, mains

eddyvisor desktop version

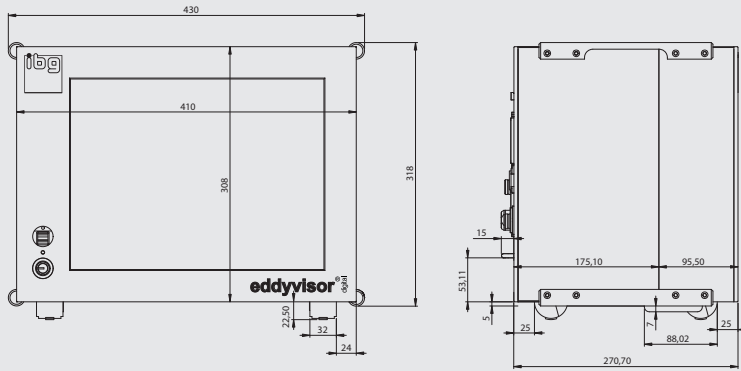

eddyvisor switch panel version

HMI

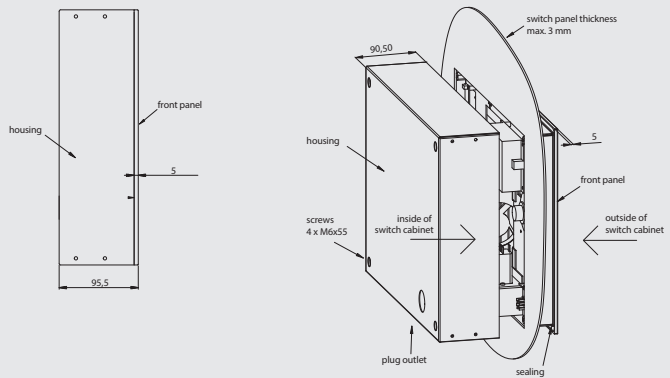
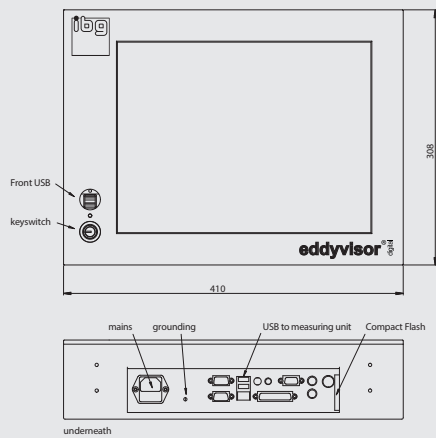

measuring unit

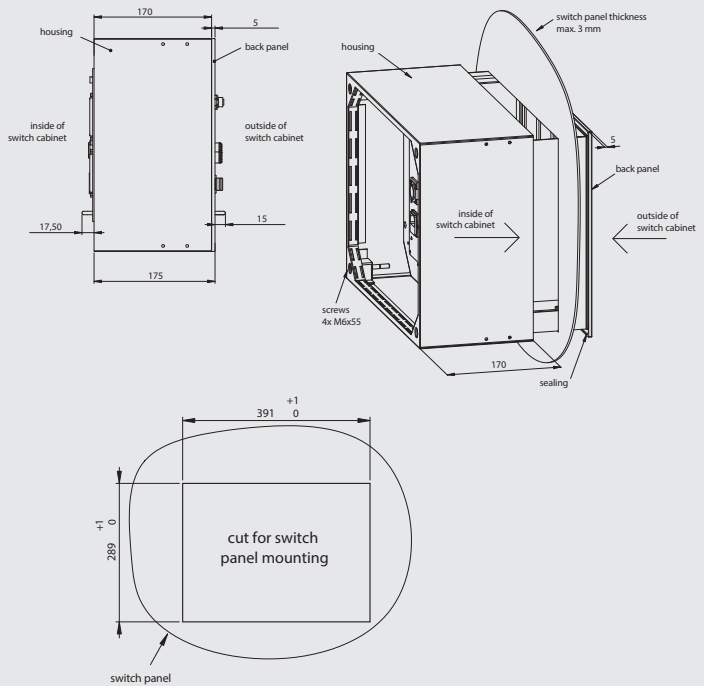
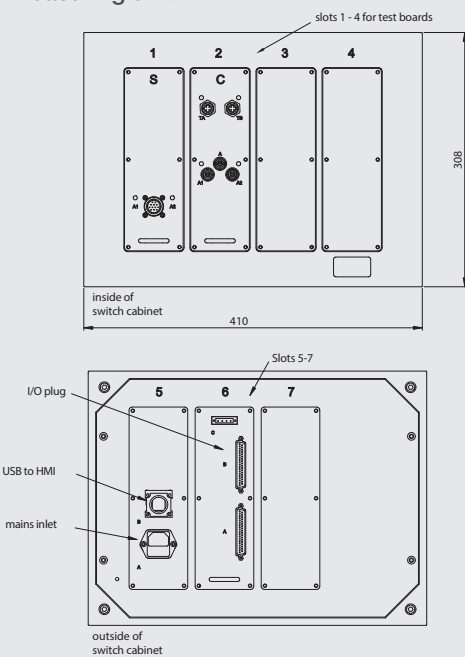



● ibg
■ ibg partners



Instruments



Coils and Probes



Automation

For more than 30 years, the ibg group has been a market leader manufacturing eddy current test instruments and setting technology standards. Whether for multi-frequency structure verification, automatic tolerance zone generation or multi-filter crack and grinder burn detection - again and again innovations and inventions of the ibg developers shape the market and provide advanced testing solution.

The headquarters is situated in Ebermannstadt, Upper Franconia, and together with subsidiaries in the US, Switzerland and Great Britain as well as a competent worldwide partner network, we service our customers in industry and automotive engineering.



Headquarters

ibg Prüfcomputer GmbH
Pretzfelder Straße 27
91320 Ebermannstadt
Germany
Tel. +49 9194 7384 -0
Fax +49 9194 7384 -10
info@ibgndt.de

Switzerland

ibg SWISS AG
Galgenried 6
6370 Stans
Switzerland
Tel. +41 41 612 26 50
Fax +41 41 612 26 51
info@ibgndt.ch

Great Britain

ibg UK Ltd.
33 Parkview Road
Sutton Coldfield,
West Midlands B74 4PR
Tel. +44 121 / 352 1188
Tel. +44 121 / 352 1188
info@ibgndt.co.uk

USA

ibg NDT Systems Corp.
20793 Farmington Rd.
Farmington Hills,
MI 48336
Tel. +1 248 478-9490
Fax +1 248 478-9491
sales@ibgndt.com