

# equotip<sup>®</sup>live

## Smart Portable Wireless Leeb Hardness Solution

From the  
inventor of Leeb



Interactive

# Equotip® Leeb D Complete Portfolio

## Equotip® Live

- Wireless
- Real-time Data Sharing
- Cloud Backup

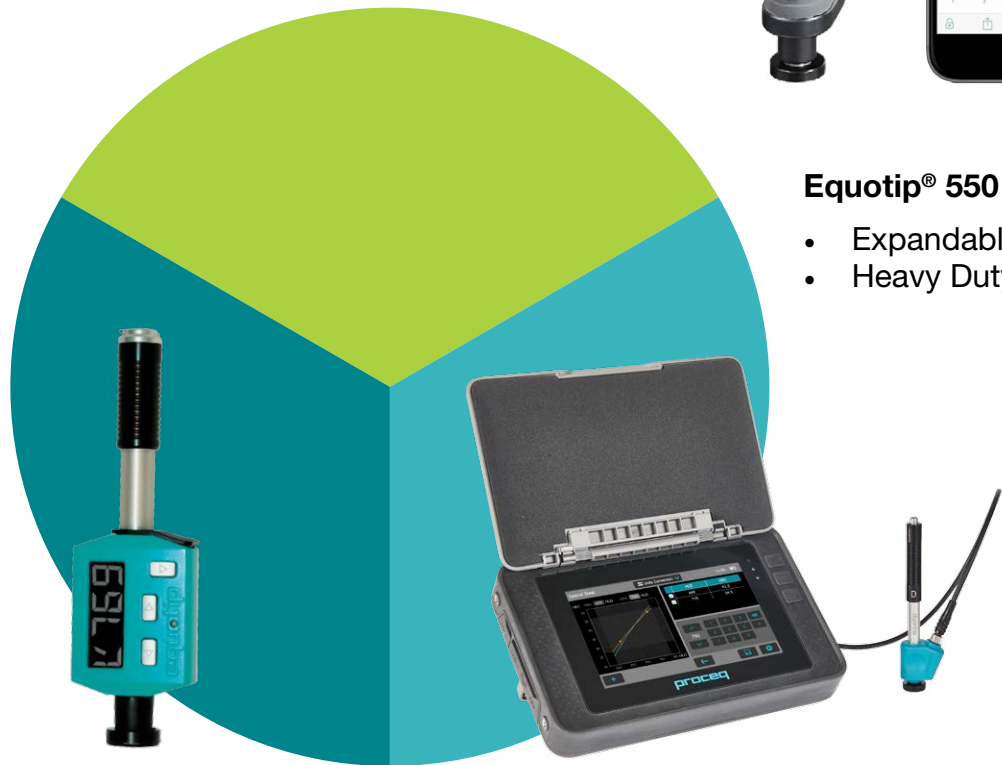

## Equotip® 550

- Expandable
- Heavy Duty

## Equotip® Piccolo / Bambino 2

- Integrated

# equotip<sup>®</sup>live

The global industry standard reinvented

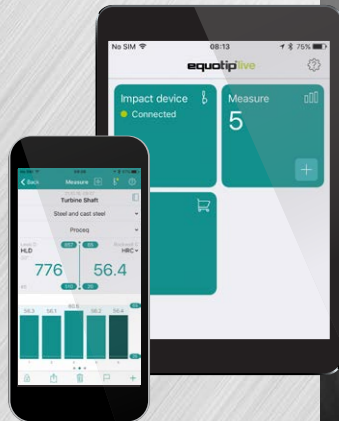

## Measure

New generation wireless impact device and mobile app



## Sync and share

Quick and easy data review and sharing

 Find out more  
(Page 4)

 Find out more  
(Page 9)

# Equotip® Live Leeb D Impact Device



**Patented  
Design**



**Loading grip**  
Innovative loading grip  
for safe operation

**Mounting ring**  
For easy and  
secure carrying

**Multi-color LED ring**  
With status indication



**On/Off button**  
And additional  
functions

**Functional materials**  
Slip proofed rubber and  
IP 54 sealed housing

**USB connector**  
For charging and  
firmware updates

**Removable Bluetooth 4.0  
low energy module**  
Built for Internet of Things (IoT)



**Exchangeable support ring**  
Compatible with existing  
Proceq accessories

**AAA battery compartment**  
Single use or rechargeable



Easy to remove for faster  
check-in and shipping

- + Following Proceq's known high quality standards and ensuring an accuracy of  $\pm 4$  HL
- + Ultra portable wireless device perfect for confined spaces on-site
- + Multiple users can share same impact device / Use multiple impact devices with the same app

## Developed for Challenging Environments



am SA, am Menge  
7.16 01.07.16 1 Stk.  
eite: 2.045  
age: 5.990

- IP 54 protected Equotip Live Leeb D Impact Device
- Special mobile covers and gloves to further increase protection
- Ultra portable solution with wireless connection
- Suitable for confined spaces

am Menge  
7.16 1 Stk.  
50  
00

# Equotip® App

## Hardness Testing Made Simple

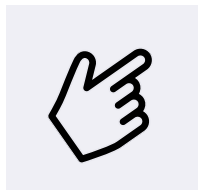

User interface designed by experts for intuitive hardness testing

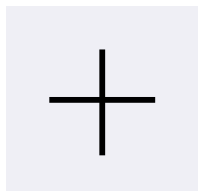

Hotspots: Predefined shortcuts for fast measuring and handling

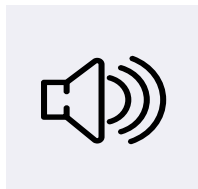

Audio output of readings allow to keep mobile device in the pocket

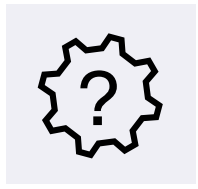

On-screen help through measuring and settings steps

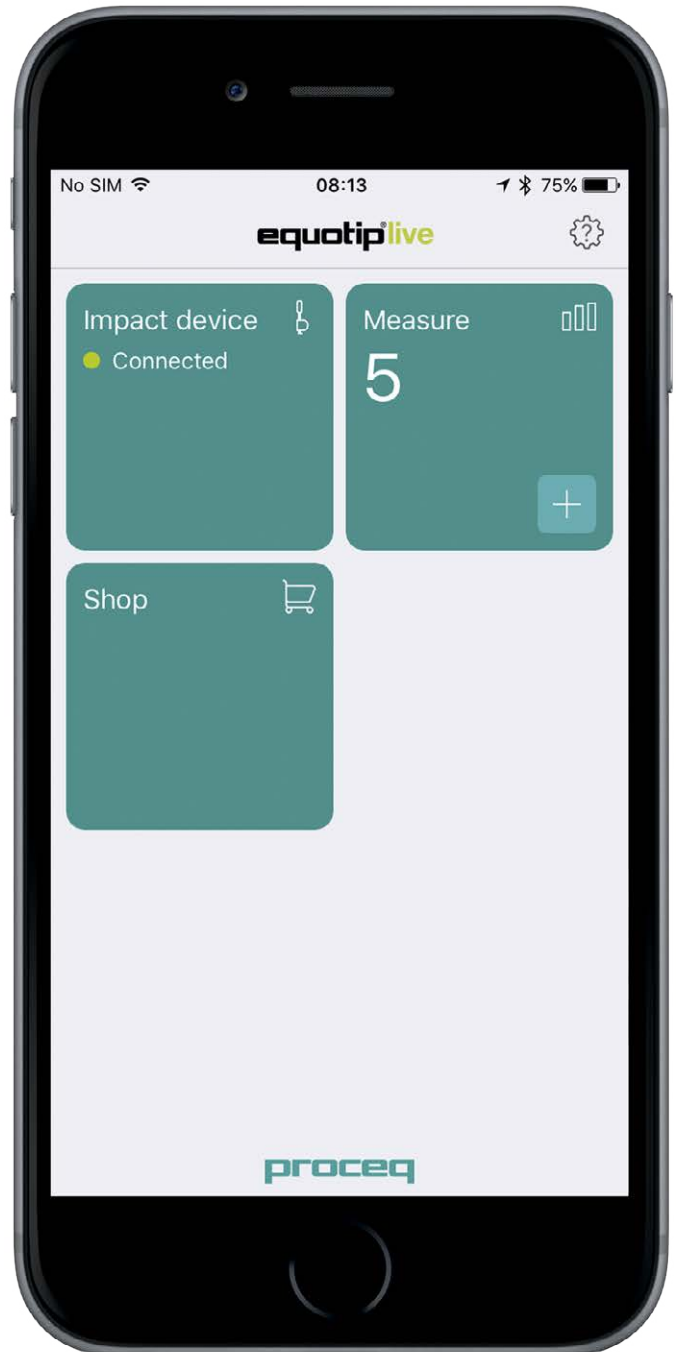

# Equotip® App

## A New Measuring Experience

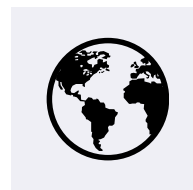
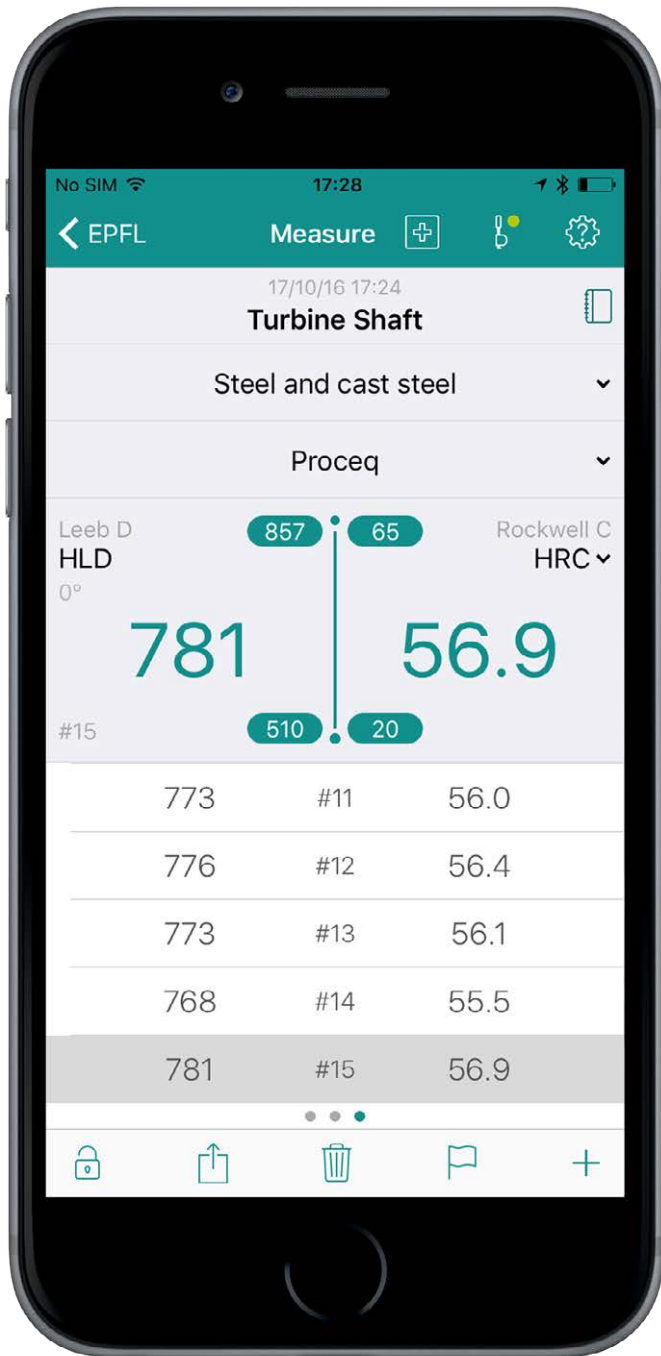

Globally accessible measuring data via [live.proceq.com](http://live.proceq.com)

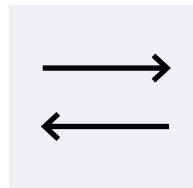

Custom conversion curve options to increase accuracy on exotic materials

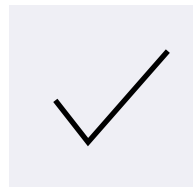

Verification and calibration information for increased reliability

- + Full traceability of data
- + Try out app: Download for free and review Proceq's training data set
- + Visit [live.proceq.com](http://live.proceq.com) for compatibility information



# Equotip® Live App

## Logbook for Full Control and Review

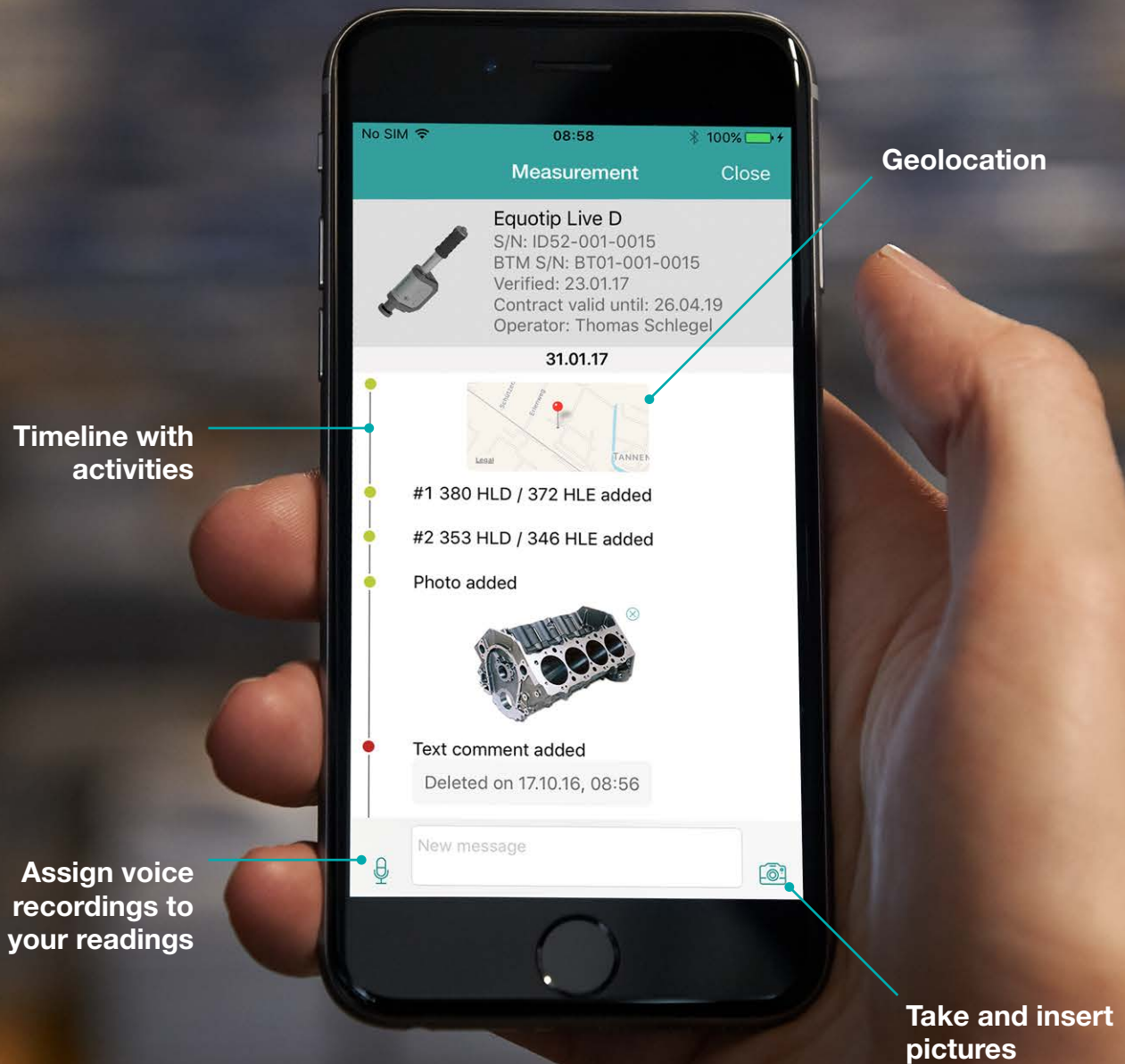



# Proceq Live Sync

## Fast and Secure Report Generation



- + Secure web platform [live.proceq.com](http://live.proceq.com)
- + Centralized report template and profile management
- + Full data traceability with continuous online backup to prevent data loss

# Equotip® Live

## First Internet of Things (IoT) Hardness Testing Solution



✓ **Flexible budgeting**  
Initial set-up contribution and small monthly fee to preserve capital for your business

✓ **Unbeatable value for your hardness solution**  
Latest technology from the inventor of Leeb for a fraction of the cost

✓ **Predictable cost planning**  
Fixed fee to help you plan well in advance

✓ **Protect your investments**  
Use existing mobile devices to leverage your IoT and Industry 4.0 investments

Experience the Equotip® Live  
At your Place

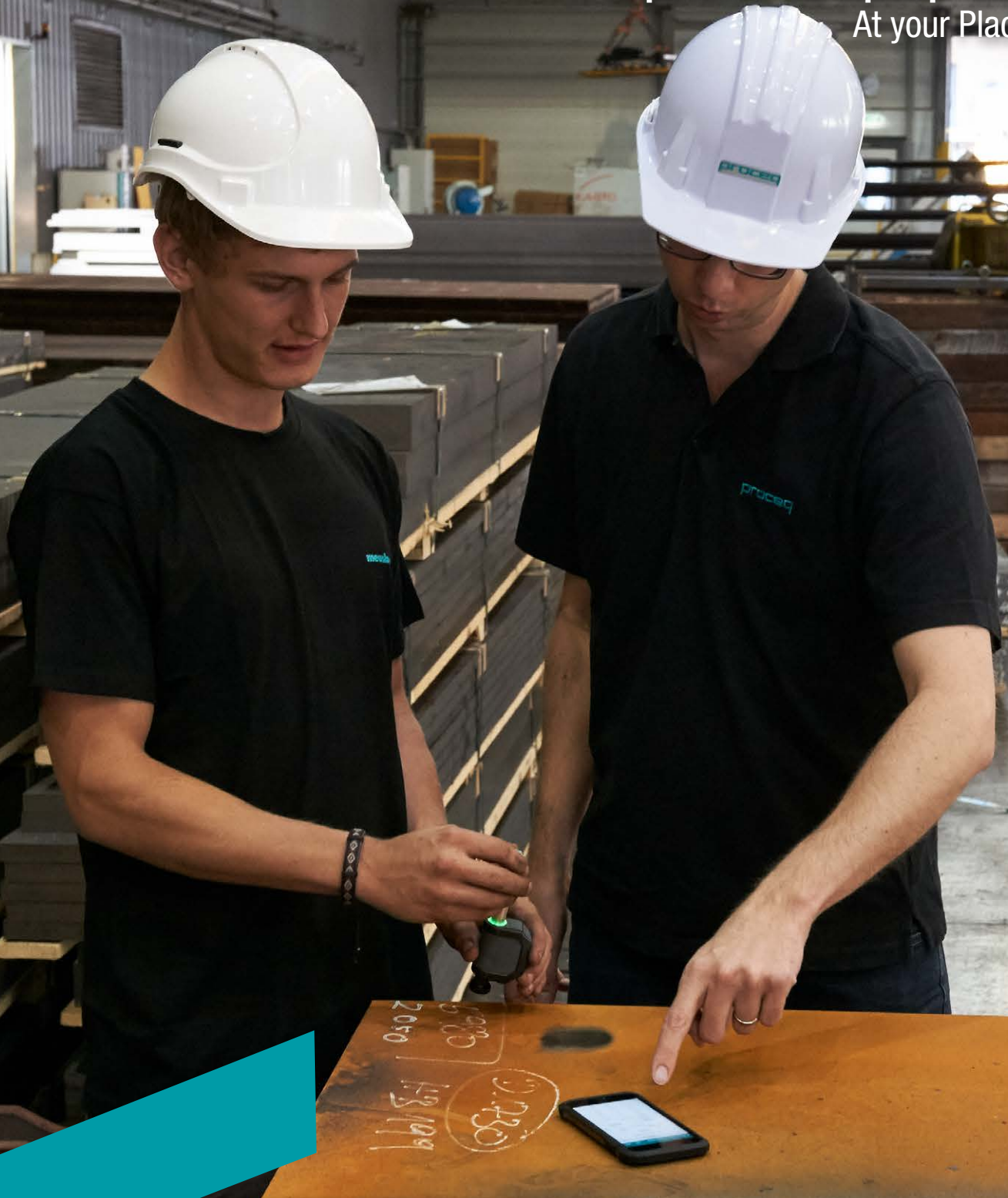

- Get professional advice and helpful hints from our experienced experts
- Global network of Proceq subsidiaries and certified business partners
- Thousands of satisfied customers worldwide thanks to superior service

# Proceq – A Story of Success



## Market Leader

Proceq SA, founded 1954 in Switzerland, is the global leader in portable measurement solutions for the non-destructive testing of material properties of metal, concrete, rock, paper and composites.

 [Find out more on the Proceq history](#)

## INVENTOR OF LEEB

INDUSTRY STANDARD

NON-DESTRUCTIVE

# equotip®

INVENTED IN 1975

PORTABLE

LEEBS

ROCKWELL

UCI



## Worldwide Local Support

Our team of dedicated experts are available to advise you on our instruments and their applications. In addition you may take further benefits from our instructional videos, evaluation tools, online webinars and of course our live seminars globally.



## Swiss Made

Proceq instruments are developed, designed and manufactured in Switzerland. Since 1994, Proceq has been certified to the ISO 9001 standards that guarantee highest quality of processes, products and services.



## Experience

Proceq has been a proud innovator in the field of portable non-destructive testing, developing solutions that have conquered the inspection industry for decades. Most famous brands are Equotip®, Schmidt®, Pundit®, Profometer® and Carboteq®.

# The Leeb Measuring Principle Invented by Proceq



Leeb hardness principle is based on the dynamic (rebound) method. An impact body with a hard metal test tip is propelled by spring force against the surface of the test piece. Surface deformation takes place when the impact body hits the test surface, which results in loss of kinetic energy. This energy loss is detected by a comparison of velocities  $v_i$  and  $v_r$  when the impact body is at a precise distance from the surface for both the impact and rebound phase of the test, respectively.

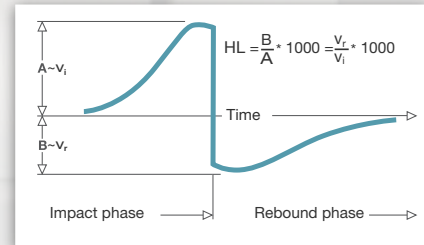

Velocities are measured using a permanent magnet in the impact body that generates an induction voltage in the coil which is precisely positioned in the impact device. The detected voltage is proportional to the velocity of the impact body. Signal processing is then providing the hardness reading.

	Scales	Units	Range
<b>Measuring Range</b>	<b>Steel and cast steel</b>	Vickers Brinell Rockwell	HV HB HRB HRC HS 30-99
		Shore Rm N/mm <sup>2</sup>	$\sigma_1$ $\sigma_2$ $\sigma_3$ 275-2194 616-1480 449-847
	<b>Cold work tool steel</b>	Vickers Rockwell	HV HRC
	<b>Stainless steel</b>	Vickers Brinell Rockwell	HV HB HRB HRC
	<b>Cast iron lamellar graphite GG</b>	Brinell Vickers Rockwell	HB HV HRC
	<b>Cast iron, nodular graphite GGG</b>	Brinell Vickers Rockwell	HB HV HRC
	<b>Cast aluminium alloys</b>	Brinell Vickers Rockwell	HB HV HRB
	<b>Copper/zinc alloys (brass)</b>	Brinell Rockwell	HB HRB
	<b>CuAl/CuSn-alloys (bronze)</b>	Brinell	HB
	<b>Wrought copper alloys, low alloyed</b>	Brinell	HB
» Other combinations possible through custom conversions			

<b>Test Piece Requirements</b>	<b>Surface preparation</b>	Roughness grade class ISO 1302	N7
		Max. roughness depth $R_z$ ( $\mu\text{m}$ / $\mu\text{inch}$ )	10 / 400
		Average roughness $R_a$ ( $\mu\text{m}$ / $\mu\text{inch}$ )	2 / 80
	<b>Minimum sample mass</b>	Of compact shape (kg / lbs)	5 / 11
		On solid support (kg / lbs)	2 / 4.5
		Coupled on plate (kg / lbs)	0.05 / 0.2
	<b>Minimum sample thickness</b>	Uncoupled (mm / inch)	25 / 0.98
		Coupled (mm / inch)	3 / 0.12
		Surface layer thickness (mm / inch)	0.8 / 0.03
	<b>Indentation size on test surface</b>	With 300 HV, 30 HRC	Diameter (mm / inch) Depth ( $\mu\text{m}$ / $\mu\text{inch}$ )
	With 600 HV, 55 HRC	Diameter (mm / inch) Depth ( $\mu\text{m}$ / $\mu\text{inch}$ )	0.45 / 0.017 17 / 680
	With 800 HV, 63 HRC	Diameter (mm / inch) Depth ( $\mu\text{m}$ / $\mu\text{inch}$ )	0.35 / 0.013 10 / 400

# Technical Specifications

## Full Standard Compliance and Traceability

### Measuring

<b>Measuring range</b>	100 - 1000 HLD
<b>Measuring accuracy</b>	± 4 HL (0.5 % at 800 HL)
<b>Measuring resolution</b>	1 HL / HV / HB 0.1 HRC / HRB / HS 1 N/mm <sup>2</sup> Rm
<b>Impact direction</b>	Automatic compensation (± 5°)
<b>Storage temperature</b>	-20 to 60° C (-4 to 140° F)
<b>Operating temperature</b>	-10 to 50° C (14 to 122° F)
<b>Charging temperature</b>	0 to 40° C (32 to 104° F)
<b>Humidity</b>	90% max.
<b>IP rating</b>	IP 54

### General

<b>Battery type</b>	1x rechargeable AAA NiMH 1000 mAh
<b>Operating hours</b>	> 20 h continuously measuring (1 impact/5 sec)
<b>Communication</b>	USB 2.0, Bluetooth 4.0 Low Energy
<b>Connector</b>	Micro-USB B

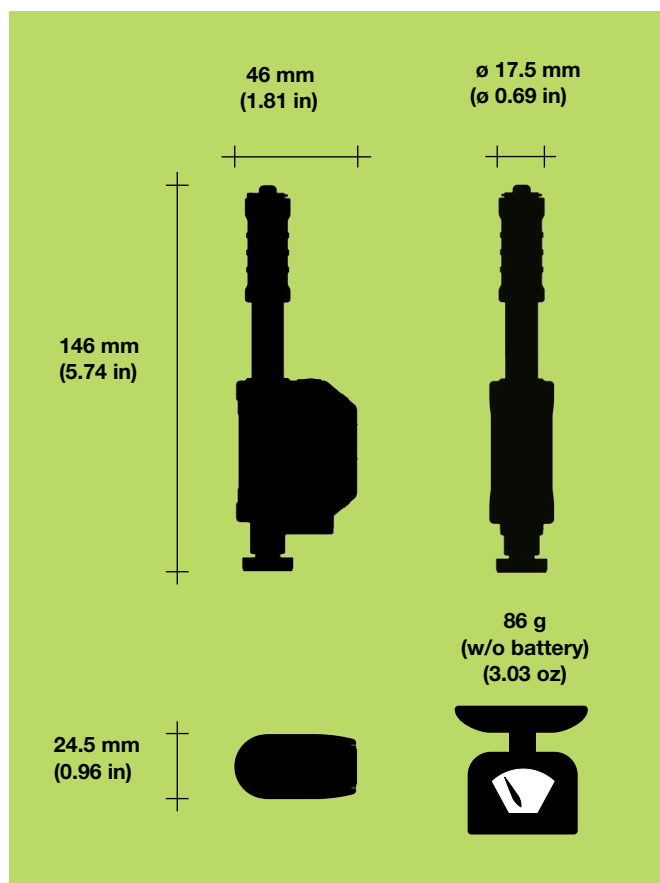

### Full Traceability

In combination with the Equotip Leeb test blocks, hardness testing with the Equotip Live solution is fully traceable.

### Standards

<b>ASTM</b>	A956 / A370
<b>ISO</b>	16859
<b>DIN</b>	50156 (withdrawn)
<b>GB/T</b>	17394
<b>JB/T</b>	9378

### Conversion Standard

<b>ASTM</b>	E140
-------------	------

### Guidelines

- ASME CRTD-91
- DGZfP Guideline MC 1
- VDI / VDE Guideline 2616 Paper 1
- Nordtest Technical Reports 421-1, 424-2, 424-3

### Equotip® Live Leeb D

Initial  
set-up  
contribution

+

Small  
monthly  
fee

- ✓ Low System Replacement Costs
- ✓ Regular Updates

358 99 002 **Rental Unlimited of Equotip Live Leeb D** consisting of Equotip Live Bluetooth module, full functionality of Equotip Live Leeb D Kit incl. usage of cloud infrastructure. Requires additionally Equotip Live Leeb D Kit.

358 10 001 **Equotip Live Leeb D Kit** consisting of Equotip Live Leeb D Basic Impact Device, Equotip Impact Body D/DC, Support Ring D6, Micro USB Cable, Cleaning Brush, Rechargeable AAA battery, Documentation, Carrying Strap and Carrying Case. Requires additionally Rental Unlimited of Equotip Live Leeb D.

#### Accessories

358 00 101	Equotip Live Leeb D Impact Device Basic
350 01 004	Equotip Impact Body D/DC
341 80 112	USB charger
350 01 015	Equotip coupling paste
350 01 010	Equotip support ring D6a
353 03 000	Set of support rings

#### Equotip Leeb Test Blocks Calibrated by Proceq

357 11 100	Equotip Test Block D/DC, <500 HLD / <220 HB
357 12 100	Equotip Test Block D/DC, ~600 HLD / ~325 HB
357 13 100	Equotip Test Block D/DC, ~775 HLD / ~56 HRC
357 13 105	Equotip Test Block D/DC, ~775 HLD, one side

#### Additional Test Block Calibrations

357 90 909	Equotip Leeb Test Block Additional Calibration HL (ISO 16859-3)
357 90 919	Equotip Leeb Test Block Additional Calibration HB (ISO 6506-3)
357 90 929	Equotip Leeb Test Block Additional Calibration HV (ISO 6507-3)
357 90 939	Equotip Leeb Test Block Additional Calibration HR (ISO 6508-3)

### Service and Support

Proceq is committed to providing the best support and service available in the industry through the Proceq certified service centers worldwide. This results in a complete support for Equotip by means of our global service and support facilities.

### Warranty Information

Each instrument is backed by the standard Proceq warranty and extended warranty options.

- » Electronic portion of the instrument: 24 months
- » Mechanical portion of the instrument: 6 months

Subject to change without notice. All information contained in this documentation is presented in good faith and believed to be correct. Proceq SA makes no warranties and excludes all liability as to the completeness and/or accuracy of the information. For the use and application of any product manufactured and/or sold by Proceq SA explicit reference is made to the particular applicable operating instructions.

 Click on the Proceq subsidiaries for more information

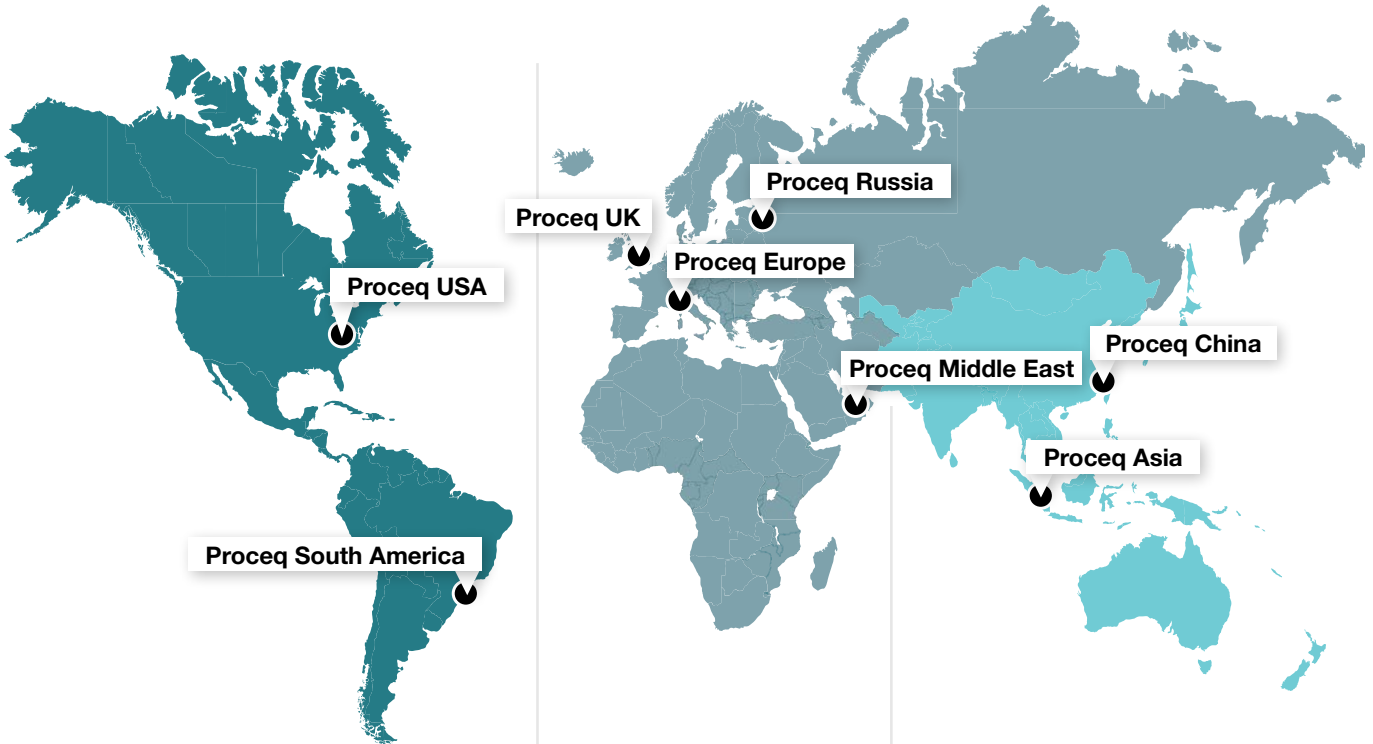

### Proceq USA

Aliquippa, Pittsburgh, USA  
Phone +1 724 512 0330  
Fax +1 724 512 0331  
info-usa@proceq.com

### Proceq South America

São Paulo, Brasil  
Phone +55 11 3083 38 89  
info-southamerica@proceq.com

### Proceq Europe

Schwerzenbach, Switzerland  
Phone +41 43 355 38 00  
Fax +41 43 355 38 12  
info-europe@proceq.com

### Proceq UK

Bedford, UK  
Phone +44 12 3483 4515  
info-uk@proceq.com

### Proceq Russia

St. Petersburg, Russia  
Phone +7 812 448 35 00  
Fax +7 812 448 35 00  
info-russia@proceq.com

### Proceq Middle East

Sharja, United Arab Emirates  
Phone +971 6 557 8505  
Fax +971 6 557 8606  
info-middleeast@proceq.com

### Proceq Asia

Singapore  
Phone +65 6382 3966  
Fax +65 6382 3307  
info-asia@proceq.com

### Proceq China

Shanghai, China  
Phone +86 21 63177479  
Fax +86 21 63175015  
info-china@proceq.com



 E-Shop USA

 E-Shop Europe

 E-Shop Asia



Globally organized seminars to help you learn more about our products and applications.  
Contact your local representative for further information.

**Z-CHECK**  
CORPORATION

35560 Grand River Ave, #420  
Farmington Hills, MI 48335  
P: 248-676-1007 / E: sales@z-checkcorp.com  
Website: www.z-checkcorp.com

### Proceq SA

Ringstrasse 2  
8603 Schwerzenbach  
Switzerland

810 356 03E ver 02 2017 © Proceq SA, Switzerland. All rights reserved.

